

Applications

- Process Industry
- Metals & Mining
- Power Industry
- Water & Waste Water
- Chemical Industry
- Pulp & Paper
- Oil & Gas

Double Door Check Valves

Pressures to 1480 PSIG
Temperatures to 600°F

DOUBLE DOOR
CHECK VALVES

FEATURES

- Compact Design
- Low Pressure Loss
- Minimal Installation Costs

MATERIALS OF CONSTRUCTION

- Cast Iron Body, Bronze & Stainless Steel Disc
- Carbon Steel Body, Stainless Steel Disc
- Stainless Steel Body, Stainless Steel Disc

END CONNECTIONS

- Wafer Flat Face
- Wafer Raised Face

SEAT MATERIALS

- Buna-N
- EPDM
- Viton
- Metal To Metal

SIZE RANGE

- 2" (50mm) up to 24" (600mm)

RATINGS

- ASME Class 125
- ASME Class 150
- ASME Class 300
- ASME Class 600

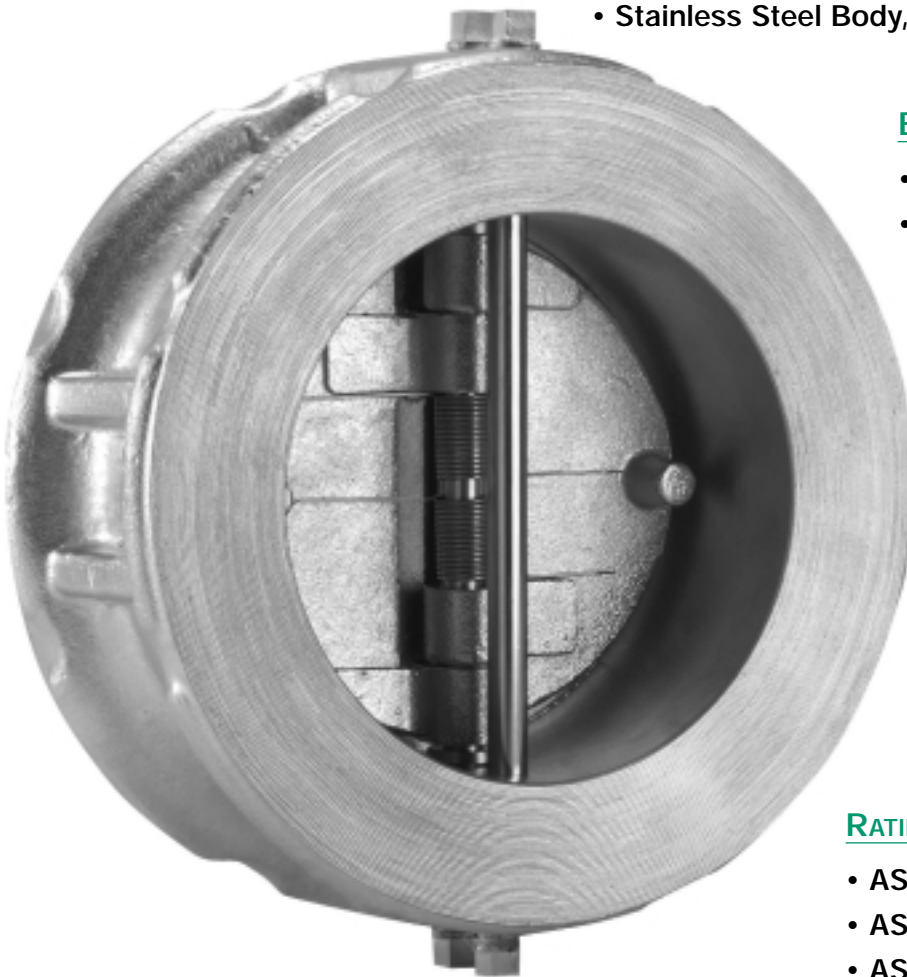

DOUBLE DOOR CHECK VALVE

DESIGN FEATURES

WAFER DOUBLE DOOR DESIGN ADVANTAGE

The short face to face design inherently makes this check valve significantly lighter (10% of the weight of a conventional swing check). The valve is designed to fit between two flanges and requires no flanges of its own. The double door check valve can be

installed in any position as the spring aids in keeping the valve closed (Consult factory for vertical downward flow). These features allow you to design your piping layout in the most efficient and least expensive fashion.

SHOCK BUMPERS

An integral cast bumper is present on all Series WT double door check valves (Except class 125 Lb.). The bumpers can be found on both discs, which meet when the valve reaches a fully open position. This design feature prevents the discs from pressing against the stop pin and eliminates leverage that would cause unnecessary stresses and wear. The purpose of the stop pin is to prevent over travel of either disc, which would result in valve failure.

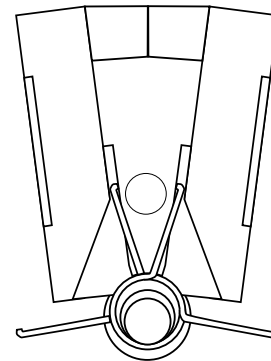

FIGURE 1

RESILIENT SEAT

The basic design of the Series WT double door check valve is illustrated in Fig. 2. This seal is chemically bonded using specially designed adhesives that provide rubber tearing bonds throughout the operating range of the seat material. In case of resilient seat failure, the design permits the

doors to float and make contact with the metal surface the seats were adhered to. This feature allows the valve to function even if the resilient seat is not present. The seat design illustrated in Fig. 3 is also available. This design results in a controlled seat squeeze and provides a metal to metal backup seal (Fig.4).

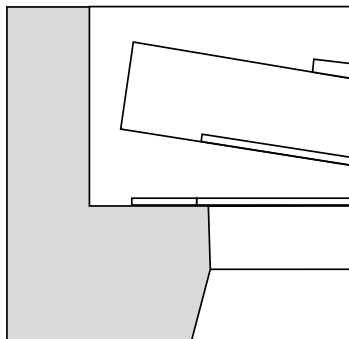

FIGURE 2

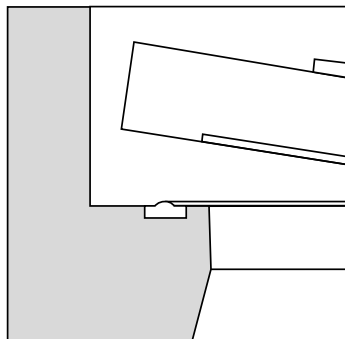

FIGURE 3

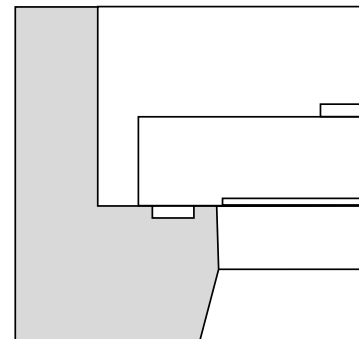

FIGURE 4

DOUBLE DOOR CHECK VALVE

DESIGN FEATURES

MINIMAL SEAT WEAR

The Series WT double door check valve was designed to eliminate the possibility of seat wear caused by friction at the heel of the double doors while maintaining low back pressure sealing capabilities. The clearance between the body, disc and hinge pin results in the discs cracking open at the

heel location first. When the valve opens the heel does not drag across the seating surface and cause wear. As the valve closes, the spring will take the toe of the disc into the seating surface first, while the line back pressure will force the heels and hinge pin back to the seat to complete the seal.

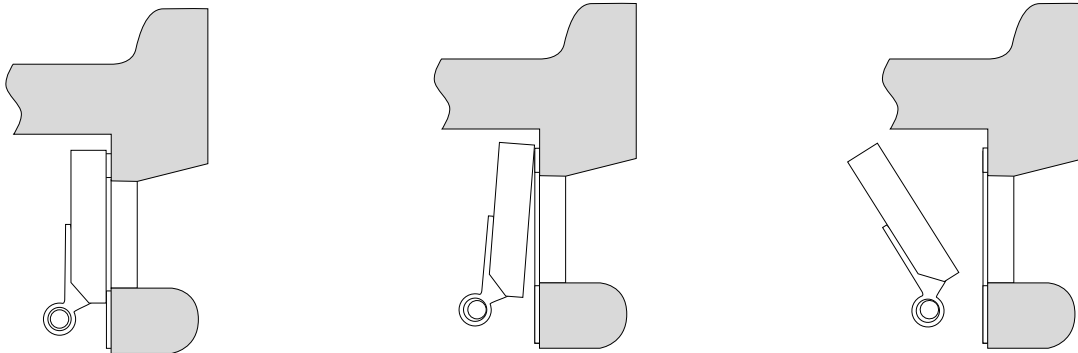

FIGURE 5

SPRING CLOSING

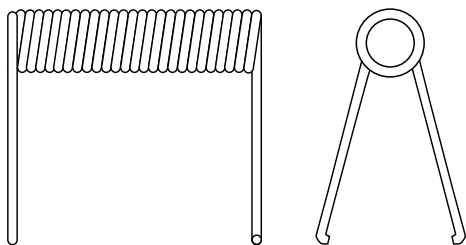

FIGURE 6

The specially designed torsion spring in the Series WT double door check valve holds the valve discs closed under no flow conditions (Consult factory for vertical downward flow). Pipeline flow (head) causes the discs to open and conversely when flow decays to a point near zero velocity, the force from the legs of the torsion spring instantly closes the valve discs for non-slam shutoff. The Series WT double door check valve comes complete with corrosion resistant stainless steel springs as standard.

125WT SERIES CAST IRON DOUBLE DOOR CHECK VALVES

SPECIFICATION

Check Valve shall be dual disc design with Cast Iron wafer body style designed to ASME B16.1 and/or ASME Sec. VIII. The check valve shall have an integral cast bumper and Buna-N resilient seat with bronze or SS discs. The check valve shall be ASME Class 125 rated. The spring shall be 316SS. The check valve shall be SSI 125WT Cast Iron Series.

MATERIALS OF CONSTRUCTION

Body A126-B Cast Iron
Discs Al/Bz B148 C954 or 316SS A351-CF8M
Seat Buna-N
Spring 316SS

CRACKING PRESSURE

Horizontal Mounting - .3psid
Vertical Mounting - .75 to 1.25 psid

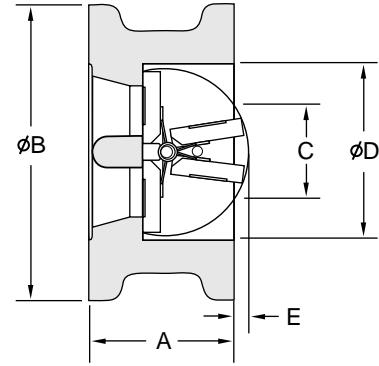
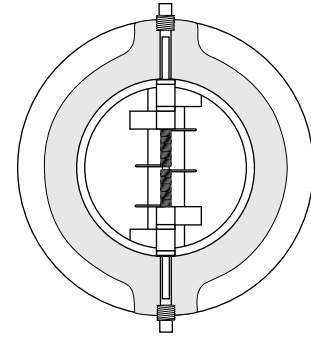

DOUBLE DOOR
CHECK VALVES

DIMENSIONS inches (mm) AND WEIGHTS pounds (kg)

| Size | A | B ¹ | C ¹ | D | E | STUD SELECTION | | | Weight |
|-------------|----------------|-----------------|-----------------|-----------------|----------------|----------------|---------------|-----------------|----------------|
| | | | | | | Qty. | Dia. | Length | |
| 2 (50) | 2 1/2 (54) | 4 1/2 (105) | 2 (51) | 2 1/2 (60) | 1/8 (3) | 4 | 5/8 (16) | 5 1/2 (140) | 3 (1.4) |
| 2.5 (65) | 2 1/2 (54) | 4 1/2 (124) | 2 1/2 (64) | 2 1/2 (73) | 1/2 (13) | 4 | 5/8 (16) | 6 (152) | 5 (2.3) |
| 3 (80) | 2 1/2 (57) | 5 1/2 (137) | 3 (76) | 3 1/2 (89) | 5/8 (16) | 4 | 5/8 (16) | 6 1/4 (159) | 8 (3.6) |
| 4 (100) | 2 1/2 (64) | 6 1/2 (175) | 4 (102) | 4 1/2 (114) | 1 (25) | 8 | 5/8 (16) | 6 1/4 (159) | 13 (5.9) |
| 5 (125) | 2 1/2 (70) | 7 1/2 (197) | 5 (127) | 5 1/2 (140) | 1 1/4 (32) | 8 | 3/4 (19) | 7 (184) | 16 (7.3) |
| 6 (150) | 3 (76) | 8 1/2 (222) | 6 (152) | 6 1/2 (168) | 1 1/2 (41) | 8 | 3/4 (19) | 8 (203) | 20 (9.8) |
| 8 (200) | 3 1/2 (95) | 11 (279) | 8 (203) | 8 1/2 (219) | 2 1/2 (60) | 8 | 3/4 (19) | 9 1/2 (241) | 37 (16.8) |
| 10 (250) | 4 1/2 (108) | 13 1/2 (340) | 10 (254) | 10 3/4 (273) | 3 (76) | 12 | 7/8 (22) | 10 1/2 (267) | 57 (25.9) |
| 12 (300) | 5 1/2 (143) | 16 1/2 (410) | 12 (305) | 12 3/4 (324) | 3 1/2 (99) | 12 | 7/8 (22) | 12 1/4 (311) | 93 (42.2) |
| 14 (350) | 7 1/2 (184) | 17 1/2 (451) | 12 1/2 (318) | 14 (356) | 4 (102) | 12 | 1 (25) | 13 (330) | 205 (93.1) |
| 16 (400) | 7 1/2 (191) | 20 1/4 (514) | 15 (381) | 16 (406) | 5 1/4 (133) | 16 | 1 (25) | 13 1/2 (343) | 271 (123.0) |
| 18 (450) | 8 (203) | 21 1/2 (549) | 17 (432) | 18 (457) | 6 (152) | 16 | 1 1/2 (29) | 14 1/2 (368) | 310 (140.7) |
| 20 (500) | 8 1/2 (213) | 23 1/2 (606) | 19 (483) | 20 (508) | 6 1/2 (175) | 20 | 1 1/2 (29) | 15 1/4 (387) | 377 (171.2) |
| 24 (600) | 8 1/2 (222) | 28 1/4 (718) | 22 1/4 (578) | 24 (610) | 8 1/4 (210) | 20 | 1 1/4 (32) | 16 1/4 (413) | 551 (250.2) |

Connections: 2" to 24"
FF Wafer Flanged

Seats: 2" to 24"
Buna-N All

Dimensions are subject to change. Consult factory for certified drawings when required.

* Add the "B" dimensions and the diameter of the stud to achieve the ANSI B16.1 bolt hole circle diameter.

1. Minimum bore diameter of companion flanges

125WT SERIES DOUBLE DOOR CHECK VALVES CAST IRON

PRESSURE DROP - LIQUIDS

Sizes 2" - 24"

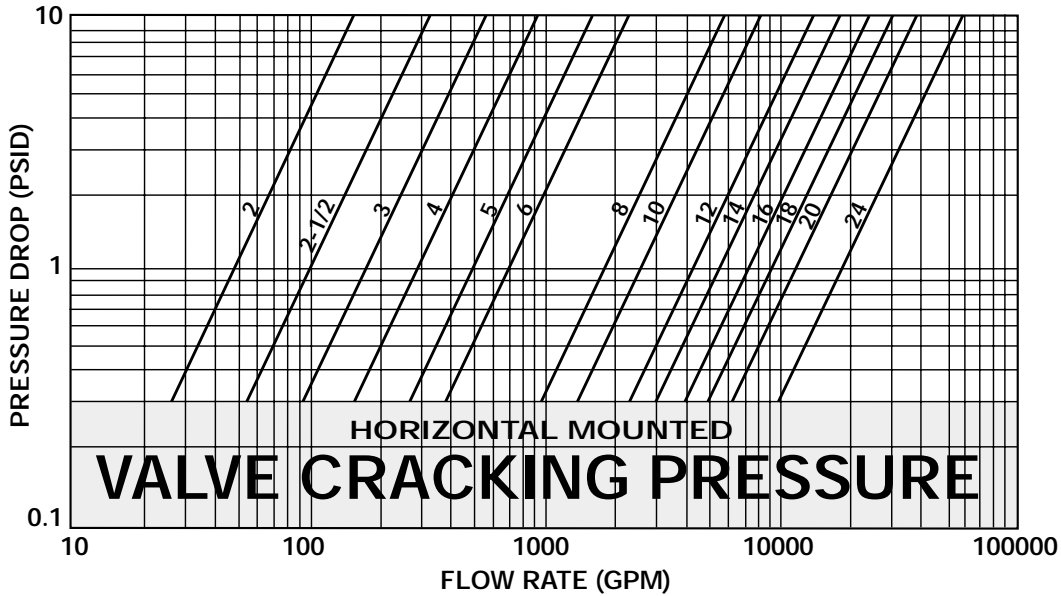

- (1) Pressure drop curves are based on water flow.
- (2) Valve cracking pressure is equal to or less than 0.3 psid when mounted horizontally.
- (3) Valve cracking pressure increases to between 0.75 and 1.25 psid when installed vertically with flow upwards.

PRESSURE DROP - AIR

Sizes 2" - 24"

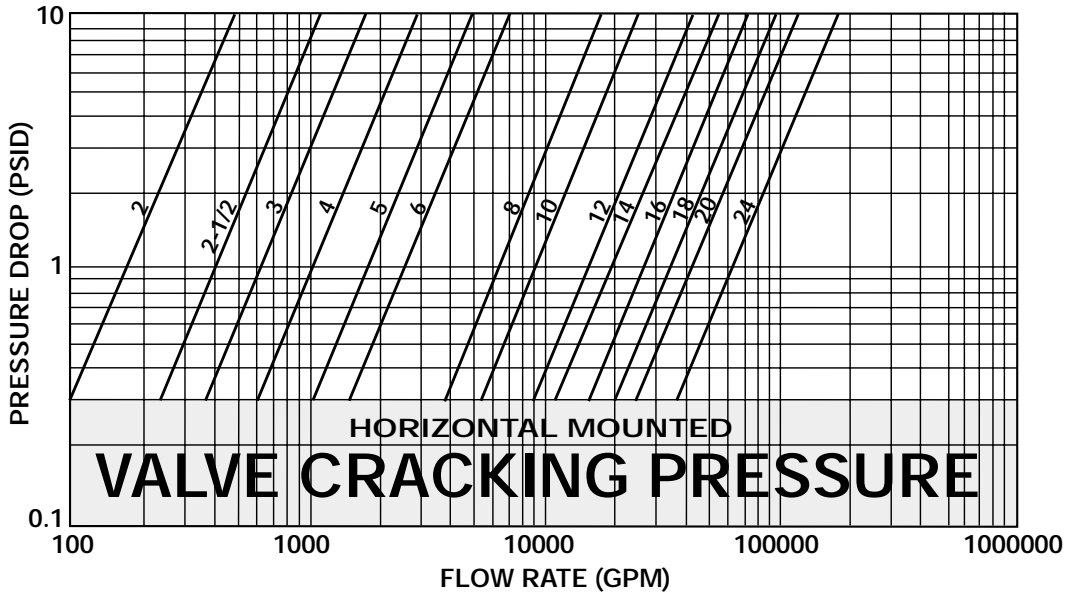

- (1) Pressure drop curves are based on air flow at 60 OF and 1 ATM pressure.
- (2) Valve cracking pressure is equal to or less than 0.3 psid when mounted horizontally.
- (3) Valve cracking pressure increases to between 0.75 and 1.25 psid when installed vertically with flow upwards.

Installation Note:

- 1) For correct installation and maintenance please see our I&M manual.
- 2) Horizontal installation – Disc pin must be installed in vertical position.
- 3) Vertical installation (downward flow) – Consult factory.

C_v VALUES (US-GPM @ 1 PSID)

| Valve Size (inches) | 2 | 2½ | 3 | 4 | 5 | 6 | 8 | 10 | 12 | 14 | 16 | 18 | 20 | 24 |
|---------------------|----|-----|-----|-----|-----|-----|------|------|------|------|------|------|------|-------|
| C _v | 60 | 100 | 170 | 340 | 520 | 850 | 1600 | 2400 | 3800 | 4400 | 5800 | 7500 | 9800 | 15000 |



NOTES:

DOUBLE DOOR
CHECK VALVES



150WT SERIES CAST STEEL AND STAINLESS STEEL DOUBLE DOOR CHECK VALVES

PRESSURES TO 285 PSIG (19.7 BARG)
TEMPERATURES TO 600°F (316°C)

DOUBLE DOOR
CHECK VALVES

APPLICATIONS

- Liquid and Air Service
- Process Industry
- Power Industry
- Chemical Industry
- Oil & Gas
- Pulp & Paper
- Metal & Mining
- Water & Waste

- ASME Class 150 rated check valves
- Wafer body style fits between FF or RF flanges
- Size 6" and larger are supplied with a valve lifting lug
- Upper and lower SS thrust washers
- Resilient Buna-N , Viton and metal seats
- Seat design lifts then swings discs to minimize seat wear
- Shock bumpers minimize stresses in hinge pins
- Independent springs optimizes valve plate closing rates while minimizing spring stress
- Dual rating 2" - 3" 150#, 300# and 600# Classes
- Dual ratings 4" 150# and 300# Classes

PRESSURE/TEMPERATURE CHART
ASME B16.34

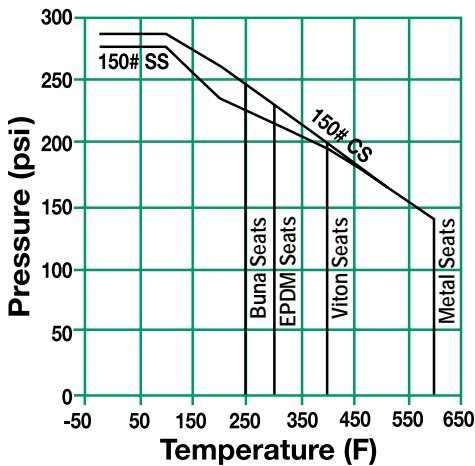

MODELS

- 150WTCT – Cast Steel Body, Stainless Steel Disc, Buna Seat
- 150WTTT – Stainless Steel Body, Stainless Steel Disc, Metal or Viton Seat

OPTIONS

- EPDM Seats
- Other Spring Material

APPLICABLE CODES

- ASME B16.34 ratings
- API 594
- API 598

Canadian Registration - OC10274.5C

150WT Series Ordering Code

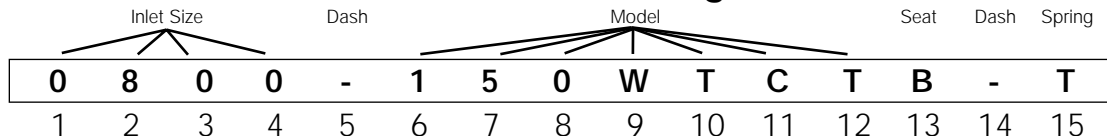

Inlet Size - Position 1 - 4
2", 2½", 3" sizes use 600WT Series.
4" size use 300WT Series
0600 - 6"
0800 - 8"
1000 - 10"
1200 - 12"

Dash - Position 5

Model - Position 6 - 12
150WTCT - CS Body
150WTTT - SS Body

Seat* - Position 13
B - Buna-N (CS Body only)
M - Metal (SS Body only)
V - Viton (SS Body only)

Dash - Position 14

Spring - Position 15
T - SS

*150WTCT - Buna-N seat only
150WTTT - Viton or Metal seat



150WT SERIES CAST STEEL AND STAINLESS STEEL DOUBLE DOOR CHECK VALVES

SPECIFICATION

Check Valve shall be dual disc design with Cast Steel or Stainless Steel Body wafer body style designed to ASME B16.34 ratings and API 594. The check valve shall have an integral cast bumper and Buna-N, Viton or metal seat with SS discs. The check valve shall be ASME Class 150 rated. The spring shall be 316SS. The seat design shall lift then swing discs to minimize seat wear. The check valve shall be SSI 150WT Series.

MATERIALS OF CONSTRUCTION

| Part | Carbon Steel | Stainless Steel |
|--------|--------------|-----------------|
| Body | A216-WCB | A351-CF8M |
| Discs | A351-CF8M | A351-CF8M |
| Seat | Buna-N | Viton or Metal |
| Spring | 304 SS | 304 SS |

CRACKING PRESSURE

Horizontal Mounting - .3psid

Vertical Mounting - .75 to 1.25 psid

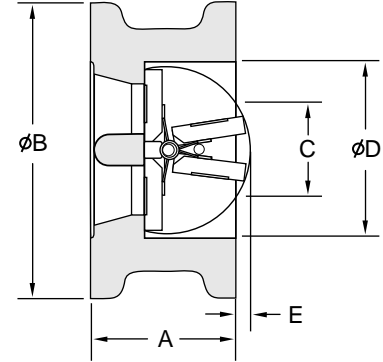
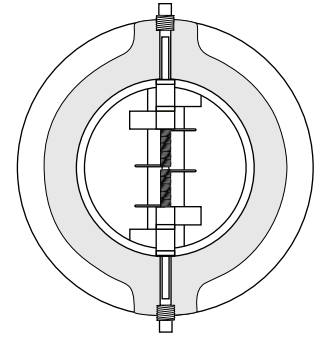

DOUBLE DOOR
CHECK VALVES

DIMENSIONS inches (mm) AND WEIGHTS pounds (kg)

| Size | A ¹ | B ² | C ² | D | E | STUD SELECTION | | | Weight |
|-------------------------|--------------------------------|----------------|----------------|--------------|------------|----------------|-------------|--------------|---------------|
| | | | | | | Qty. | Dia. | Length | |
| 2 ³ (50) | Use 2" 600WT-150# on page 191 | | | | | | | | |
| 2½ (66) | Use 2½" 600WT-150# on page 191 | | | | | | | | |
| 3 ³ (80) | Use 3" 600WT-150# on page 191 | | | | | | | | |
| 4 ⁴ (100) | Use 4" 300WT-150# on page 187 | | | | | | | | |
| 6 (150) | 3½ (99) | 8¼ (222) | 5½ (137) | 6½ (168) | 1½ (35) | 8 | ¾ (19) | 8¼ (210) | 35 (15.9) |
| 8 (200) | 5 (127) | 11 (279) | 7½ (187) | 8½ (219) | 2 (51) | 8 | ¾ (19) | 9¼ (248) | 70 (31.8) |
| 10 (250) | 5¾ (146) | 13¾ (340) | 9½ (241) | 10¾ (273) | 2½ (73) | 12 | 7/8 (22) | 11 (279) | 114 (51.8) |
| 12 (300) | 7½ (181) | 16½ (410) | 11¼ (286) | 12¾ (324) | 3½ (86) | 12 | 7/8 (22) | 12¼ (311) | 180 (81.8) |

Connections: 6" to 12"
RF Wafer Flanged

Seats:
CS Body - 6" to 12" Buna-N
SS Body - 6" to 12" Viton or Metal

- Dimensions in accordance with API 594.
- Minimum bore diameter of companion flanges.
- Sizes 2", 2½", 3" 150WT, 300WT & 600WT are interchangeable, use 600WT for all applications in these sizes.
- Size 4", 150WT & 300WT are interchangeable, use 300WT for 4" size.

* Add the "B" dimension and the diameter of the stud to achieve the ANSI B16.5 bolt hole circle diameter.

150WT SERIES DOUBLE DOOR CHECK VALVES

CAST STEEL AND STAINLESS STEEL

PRESSURE DROP - LIQUIDS

Sizes 6" - 12"

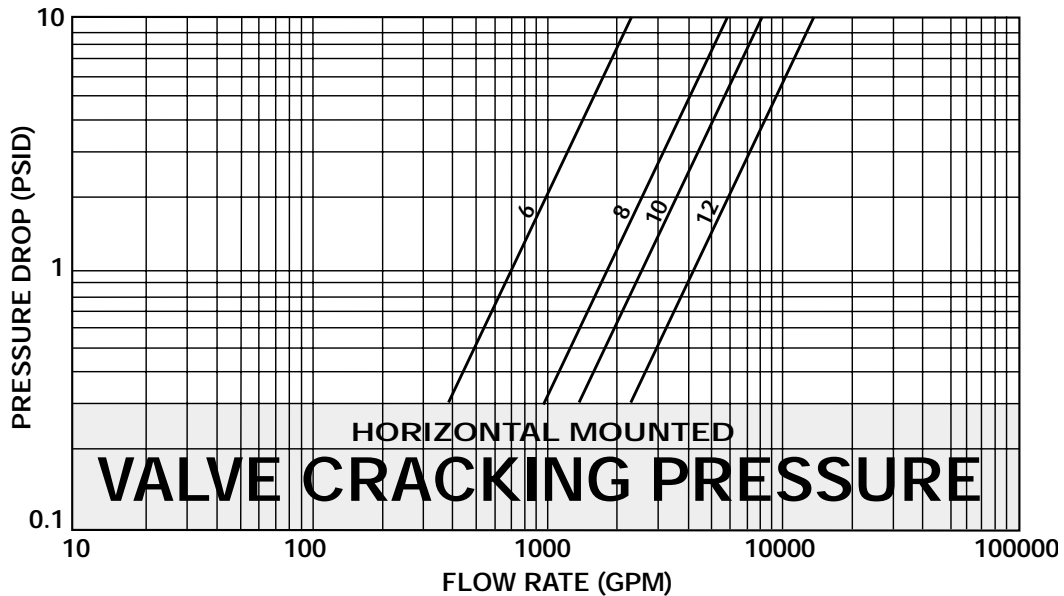

- (1) Pressure drop curves are based on water flow.
- (2) Valve cracking pressure is equal to or less than 0.3 psid when mounted horizontally.
- (3) Valve cracking pressure increases to between 0.75 and 1.25 psid when installed vertically with flow upwards.

PRESSURE DROP - AIR

Sizes 6" - 12"

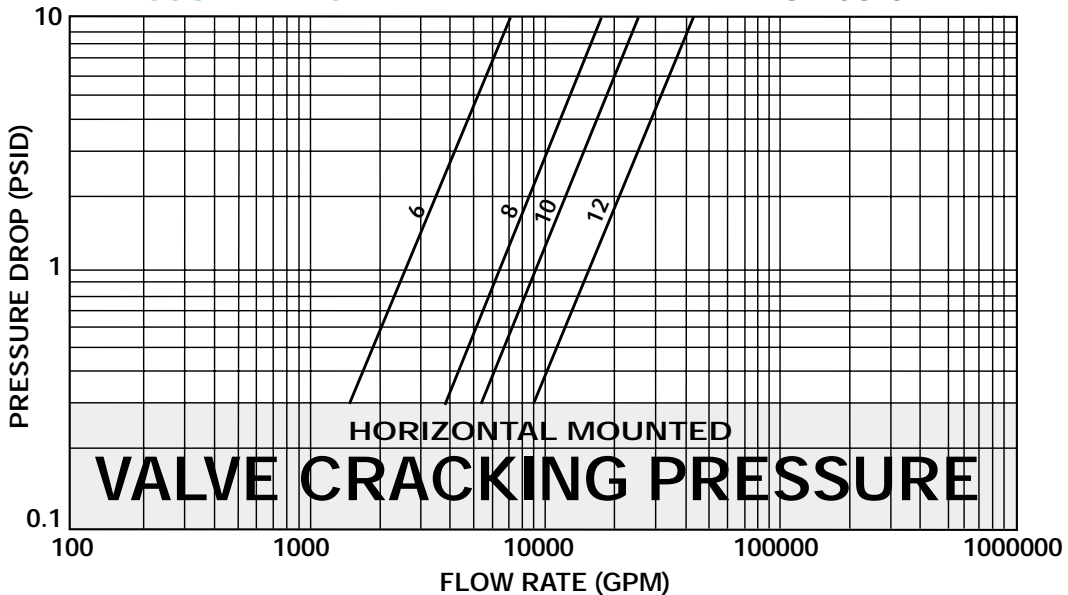

- (1) Pressure drop curves are based on air flow at 60 OF and 1 ATM pressure.
- (2) Valve cracking pressure is equal to or less than 0.3 psid when mounted horizontally.
- (3) Valve cracking pressure increases to between 0.75 and 1.25 psid when installed vertically with flow upwards.

Installation Note:

- 1) For correct installation and maintenance please see our I&M manual.
- 2) Horizontal installation – Disc pin must be installed in vertical position.
- 3) Vertical installation (downward flow) – Consult factory.

C_v VALUES (US-GPM @ 1 PSID)

| Valve Size (inches) | 6 | 8 | 10 | 12 |
|---------------------|-----|------|------|------|
| C _v | 705 | 1795 | 2563 | 4295 |



NOTES:

DOUBLE DOOR
CHECK VALVES

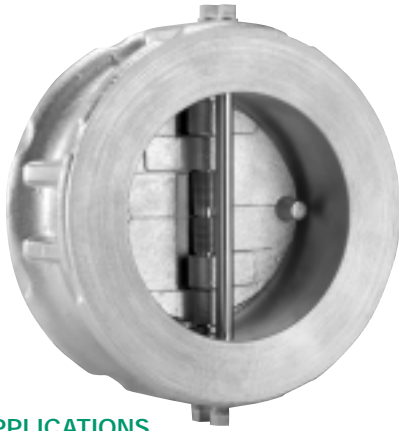

300WT SERIES CAST STEEL AND STAINLESS STEEL DOUBLE DOOR CHECK VALVES

PRESSURES TO 740 PSIG (51 BARG)
TEMPERATURES TO 600°F (316°C)

APPLICATIONS

- Liquid and Air Service
- Process Industry
- Power Industry
- Chemical Industry
- Oil & Gas
- Pulp & Paper
- Metal & Mining
- Water & Waste

- ASME Class 300 rated check valves
- Wafer body style fits between FF or RF flanges
- Size 6" and larger are supplied with a valve lifting lug
- Upper and lower SS thrust washers
- Resilient Buna-N and Viton
- Seat design lifts then swings discs to minimize seat wear
- Shock bumpers minimize stresses in hinge pins
- Independent springs optimizes valve plate closing rates while minimizing spring stress
- Dual ratings 2"-3" 150#, 300# and 600#.
- Dual ratings 4" 150# and 300#.

PRESSURE/TEMPERATURE CHART

ASME B16.34

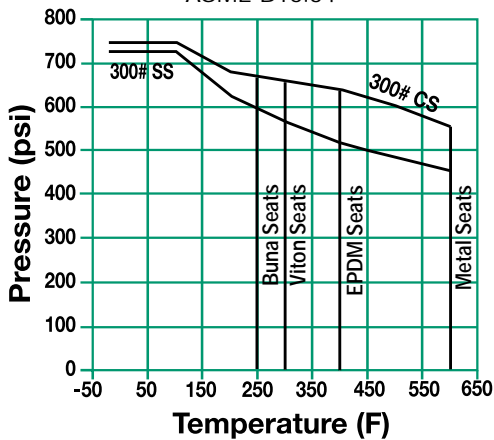

Contact factory for EPDM pressure/temperature range.

MODELS

- 300WTCT – Cast Steel Body, Stainless Steel Disc, Buna Seat
- 300WTTT – Stainless Steel Body, Stainless Steel Disc, Viton Seat

OPTIONS (CONSULT FACTORY)

- EPDM Seats
- Other Spring Material

APPLICABLE CODES

- ASME B16.34 ratings
- API 594
- API 598

Canadian Registration - OC10274.5C

300WT Series Ordering Code

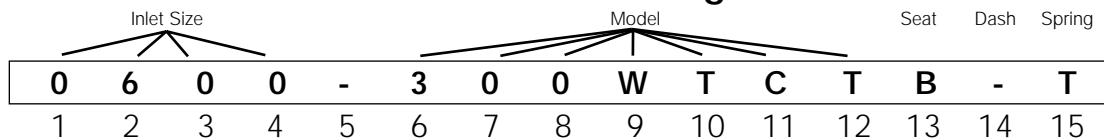

Inlet Size* - Position 1 - 4
 2", 2½", 3" sizes use 600WT Series
 0400 - 4"
 0600 - 6"
 0800 - 8"
 1000 - 10"
 1200 - 12"

Dash - Position 5

Model - Position 6 - 12
 300WTCT - CS Body
 300WTTT - SS Body

Seat* - Position 13
 B - Buna-N (CS Body only)
 V - Viton (SS Body only)

Dash - Position 14

Spring - Position 15
 T - SS

*300WTCT - Buna-N seat only
 300WTTT - Viton seat only

300WT SERIES CAST STEEL AND STAINLESS STEEL DOUBLE DOOR CHECK VALVES

SPECIFICATION

Check Valve shall be dual disc design with Cast Steel or Stainless Steel Body wafer body style designed to ASME B16.34 ratings and API 594. The check valve shall have an integral cast bumper and Buna-N or Viton resilient seats with SS discs. The check valve shall be ASME Class 300 rated. The spring shall be 316SS. The seat design shall lift then swing discs to minimize seat wear. The check valve shall be SSI 300WT Series..

MATERIALS OF CONSTRUCTION

| Part | Carbon Steel | Stainless Steel |
|--------|--------------|-----------------|
| Body | A216-WCB | A351-CF8M |
| Discs | A351-CF8M | A351-CF8M |
| Seat | Buna-N | Viton |
| Spring | 304 SS | 304 SS |

CRACKING PRESSURE

Horizontal Mounting - .3psid

Vertical Mounting - .75 to 1.25 psid

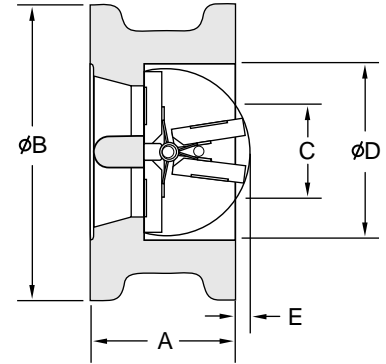
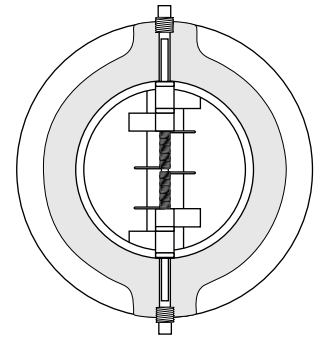

DOUBLE DOOR
CHECK VALVES

Connections: 4" to 12"
Wafer Flanged

Seats:
CS Body - 4" to 12" Buna-N
SS Body - 4" to 12" Viton

DIMENSIONS inches (mm) AND WEIGHTS pounds (kg)

| Size | A ¹ | B [*] | C ² | D | E | STUD SELECTION | | | Weight | |
|-------------------------|--------------------------------|----------------|----------------|--------------|--------------|----------------|------|-------------|--------------|---------------|
| | | | | | | Qty. | Dia. | Length | | |
| 2 ³ (50) | Use 2" 600WT 300# on page 191 | | | | | | | | | |
| 2½ ³ (66) | Use 2½" 600WT 300# on page 191 | | | | | | | | | |
| 3 ³ (80) | Use 3" 600WT 300# on page 191 | | | | | | | | | |
| 4 ⁴ (100) | 150WT | 2⅞ (73) | 6⅞ (175) | 3⅞ (86) | 4½ (114) | ¾ (19) | 8 | ⅝ (16) | 7 (178) | 18 (8.2) |
| | 300WT | 2⅞ (73) | 7⅞ (181) | 3⅞ (86) | 4½ (114) | ¾ (19) | 8 | ¾ (19) | 8⅞ (207) | 18 (8.2) |
| 6 (150) | | 3⅞ (99) | 9⅞ (251) | 5⅞ (137) | 6⅞ (168) | 1⅞ (35) | 12 | ¾ (19) | 9⅞ (245) | 44 (20.0) |
| 8 (200) | | 5 (127) | 12⅞ (308) | 7⅞ (187) | 8⅞ (219) | 2 (51) | 12 | 7/8 (22) | 11¼ (286) | 75 (34.0) |
| 10 (250) | | 5⅞ (146) | 14¼ (362) | 9½ (241) | 10¼ (273) | 2⅞ (73) | 16 | 1 (25) | 12¼ (324) | 123 (55.8) |
| 12 (300) | | 7⅞ (181) | 16⅞ (422) | 11¼ (286) | 12¼ (324) | 3⅞ (86) | 16 | 1⅞ (29) | 14⅞ (372) | 196 (89.0) |

1. Dimensions in accordance with API 594.
2. Minimum bore diameter of companion flanges.
3. Sizes 2", 2½" & 3" for 150WT, 300WT & 600WT are interchangeable, use 600WT for all applications in these sizes.
4. Size 4" for 150WT & 300WT are interchangeable, use 300WT for 4" size. 4" sizes fit between both 150# & 300# flanges.

* Add the "B" dimension and the diameter of the stud to achieve the ANSI B16.5 bolt hole circle diameter.

300WT SERIES DOUBLE DOOR CHECK VALVES

CAST STEEL AND STAINLESS STEEL

PRESSURE DROP - LIQUIDS

Sizes 4" - 12"

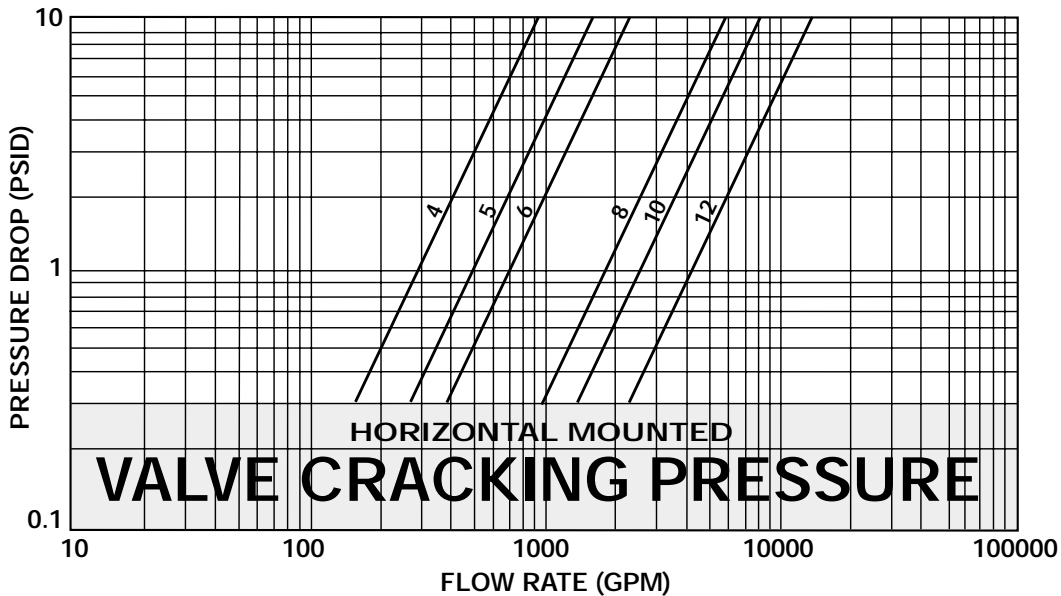

- (1) Pressure drop curves are based on water flow.
- (2) Valve cracking pressure is equal to or less than 0.3 psid when mounted horizontally.
- (3) Valve cracking pressure increases to between 0.75 and 1.25 psid when installed vertically with flow upwards.

PRESSURE DROP - AIR

Sizes 4" - 12"

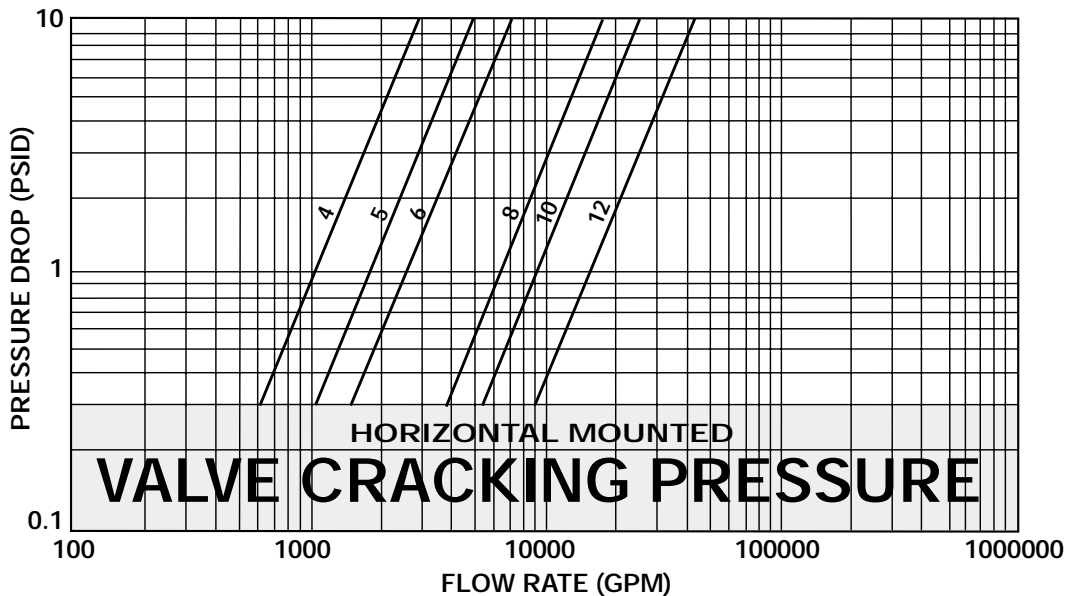

- (1) Pressure drop curves are based on air flow at 60 OF and 1 ATM pressure.
- (2) Valve cracking pressure is equal to or less than 0.3 psid when mounted horizontally.
- (3) Valve cracking pressure increases to between 0.75 and 1.25 psid when installed vertically with flow upwards.

Installation Note:

- 1) For correct installation and maintenance please see our I&M manual.
- 2) Horizontal installation – Disc pin must be installed in vertical position.
- 3) Vertical installation (downward flow) – Consult factory.

C_v VALUES (US-GPM @ 1 PSID)

| Valve Size (inches) | 4 | 5 | 6 | 8 | 10 | 12 |
|---------------------|-----|-----|-----|------|------|------|
| C _v | 291 | 494 | 705 | 1795 | 2563 | 4295 |



NOTES:

DOUBLE DOOR
CHECK VALVES

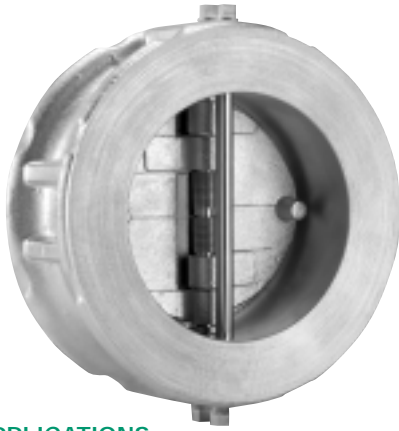

600WT SERIES CAST STEEL AND STAINLESS STEEL DOUBLE DOOR CHECK VALVES

PRESSURES TO 1480 PSIG (101.9 BARG)
TEMPERATURES TO 600°F (316°C)

- ASME Class 600 rated check valves
- Wafer body style fits between FF or RF flanges
- Upper and lower SS thrust washers
- Resilient Buna-N , Viton and metal seats
- Seat design lifts then swings discs to minimize seat wear
- Shock bumpers minimize stresses in hinge pins
- Independent springs optimizes valve plate closing rates while minimizing spring stress
- Dual ratings 2"-3" 150#, 300# and 600#.

APPLICATIONS

- Liquid and Air Service
- Process Industry
- Power Industry
- Chemical Industry
- Oil & Gas
- Pulp & Paper
- Metal & Mining
- Water & Waste

PRESSURE/TEMPERATURE CHART
ASME B16.34

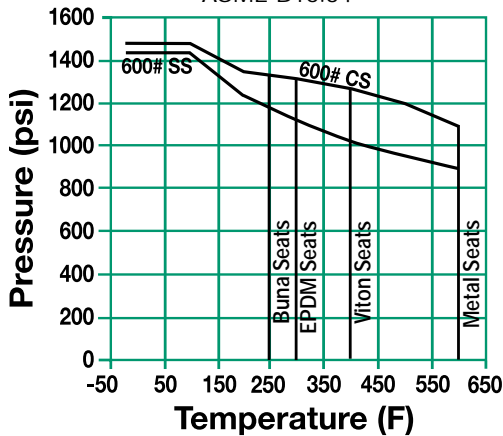

MODELS

- 600WTCT – Cast Steel Body, Stainless Steel Disc, Buna Seat
- 600WTTT – Stainless Steel Body, Stainless Steel Disc, Metal or Viton Seats

OPTIONS (Consult Factory)

- EPDM Seats
- Other Spring Material

APPLICABLE CODES

- ASME B16.34 ratings
- API 594
- API 598

Canadian Registration - OC10274.5C

600WT Series Ordering Code



Inlet Size* - Position 1 - 4
0200 - 2"
0250 - 2½"
0300 - 3"

Dash - Position 5

Model - Position 6 - 12
300WTCT - CS Body
300WTTT - SS Body

Seat** - Position 13
B - Buna-N (CS Body only)
M - Metal (SS Body only)
V - Viton (SS Body only)

Dash - Position 14

Spring - Position 15
T - SS

* For sizes 2", 2½", 3"
600WT check valves fit
between all ANSI 150#,
300# & 600# class flanges.

** 600WTCT - Buna-N seat only,
600WTTT - Viton or Metal seat

600WT SERIES CAST STEEL AND STAINLESS STEEL DOUBLE DOOR CHECK VALVES

SPECIFICATION

Check Valve shall be dual disc design with Cast Steel or Stainless Steel Body wafer body style designed to ASME B16.34 and API 594. The check valve shall have an integral cast bumper and Buna-N or Viton resilient seats with SS discs. The check valve shall be ASME Class 600 rated. The spring shall be 316SS. The seat design shall lift then swing discs to minimize seat wear. The check valve shall be SSI 300WT Series.

MATERIALS OF CONSTRUCTION

| Part | Carbon Steel | Stainless Steel |
|--------|--------------|-----------------|
| Body | A216-WCB | A351-CF8M |
| Discs | A351-CF8M | A351-CF8M |
| Seat | Buna-N | Viton or Metal |
| Spring | 304 SS | 304 SS |

CRACKING PRESSURE

Horizontal Mounting - .3psid

Vertical Mounting - .75 to 1.25 psid

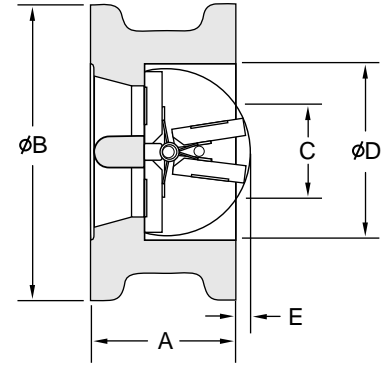
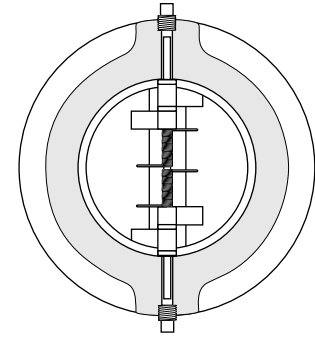

DOUBLE DOOR
CHECK VALVES

Connections: 2" to 3"
Wafer Flanged

Seats:
CS Body - 2" to 3" Buna-N
SS Body - 2" to 3" Viton or Metal

DIMENSIONS inches (mm) AND WEIGHTS pounds (kg)

| Size | | A ¹ | B* | C ² | D | E | STUD SELECTION | | | Weight |
|----------------------------|---------------|----------------|----------------|----------------|---------------|------------|----------------|---------------|----------------|-------------|
| | | | | | | | Qty. | Dia. | Length | |
| 2 ³ (50) | 150# | 2 1/2 (60) | 4 1/2 (105) | — | 2 1/2 (60) | — | 4 | 5/8 (15.9) | 6 (152) | 6 (2.7) |
| | 300#/ 600# | 2 1/2 (60) | 4 3/4 (111) | — | 2 1/2 (60) | — | 8 | 5/8 (15.9) | 6 1/2 (175) | 6 (2.7) |
| 2 1/2 ³ (65) | 150# | 2 1/2 (67) | 4 1/2 (124) | 2 (51) | 3 (77) | 1/4 (6) | 4 | 5/8 (15.9) | 6 1/2 (159) | 10 (4.5) |
| | 300#/ 600# | 2 1/2 (67) | 5 1/2 (130) | 2 (51) | 3 (77) | 1/4 (6) | 8 | 3/4 (19) | 7 1/2 (190) | 10 (4.5) |
| 3 ³ (80) | 150# | 2 1/2 (73) | 5 1/2 (137) | 2 (51) | 3 1/2 (89) | 1/4 (6) | 4 | 5/8 (15.9) | 7 (178) | 13 (5.9) |
| | 300#/ 600# | 2 1/2 (73) | 5 3/4 (149) | 2 (51) | 3 1/2 (89) | 1/4 (6) | 8 | 3/4 (19) | 8 1/2 (207) | 13 (5.9) |

1. Dimensions in accordance with API 594.
2. Minimum diameter of companion flanges.
3. 300WT and 600WT are interchangeable, use 600WT for both applications.

Dimensions are subject to change. Consult factory for certified drawings when required.

* Add the "B" dimension and the diameter of the stud to achieve the ANSI B16.5 bolt hole circle diameter.

600WT SERIES DOUBLE DOOR CHECK VALVES

CAST STEEL AND STAINLESS STEEL

PRESSURE DROP - LIQUIDS

Sizes 2" - 3"

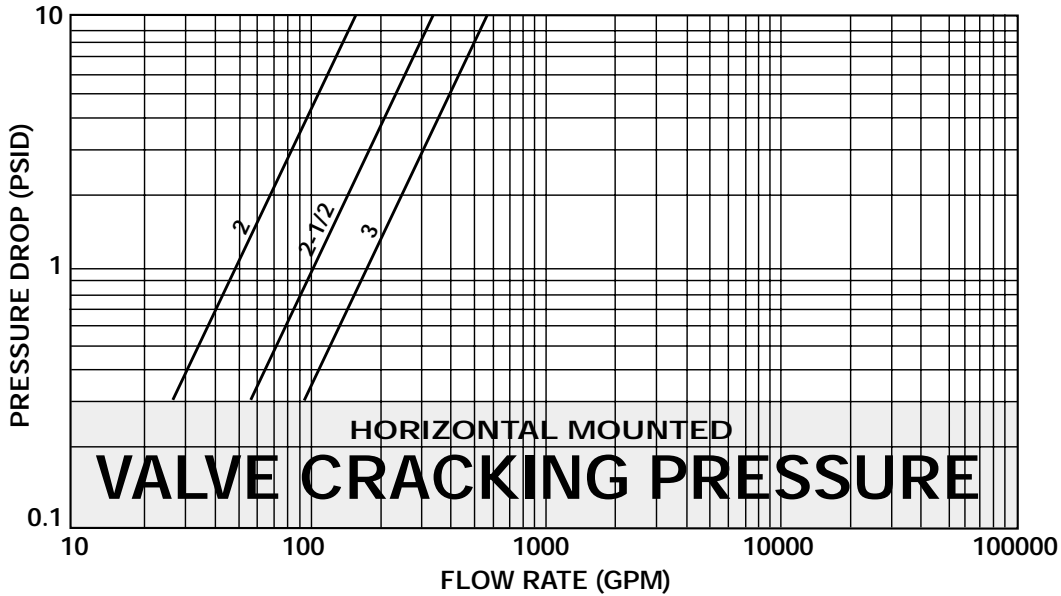

- (1) Pressure drop curves are based on water flow.
- (2) Valve cracking pressure is equal to or less than 0.3 psid when mounted horizontally.
- (3) Valve cracking pressure increases to between 0.75 and 1.25 psid when installed vertically with flow upwards.

PRESSURE DROP - AIR

Sizes 2" - 3"

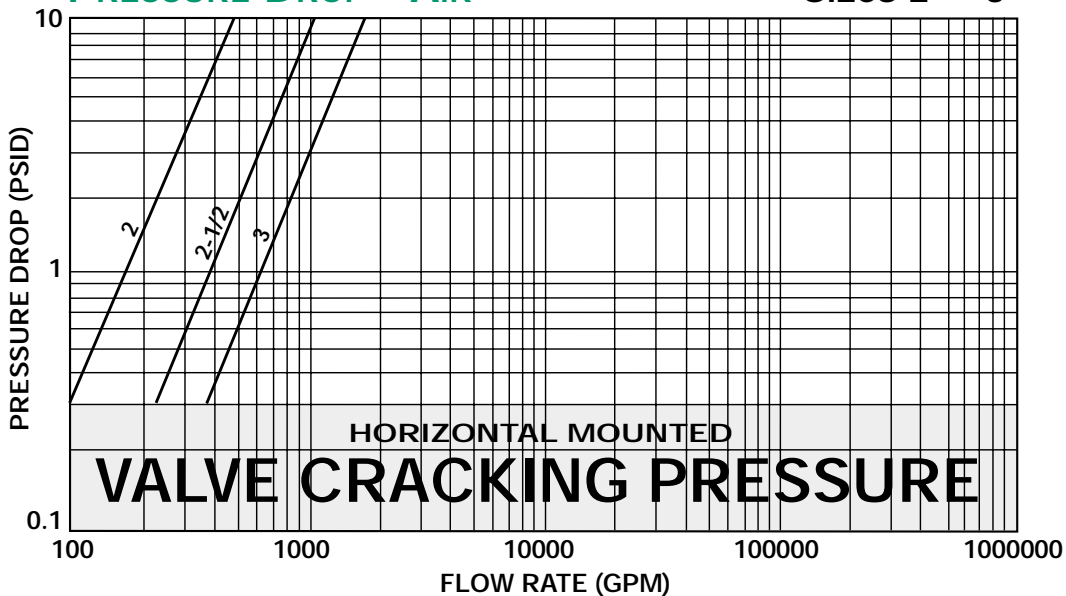

- (1) Pressure drop curves are based on air flow at 60 OF and 1 ATM pressure.
- (2) Valve cracking pressure is equal to or less than 0.3 psid when mounted horizontally.
- (3) Valve cracking pressure increases to between 0.75 and 1.25 psid when installed vertically with flow upwards.

Installation Note:

- 1) For correct installation and maintenance please see our I&M manual.
- 2) Horizontal installation – Disc pin must be installed in vertical position.
- 3) Vertical installation (downward flow) – Consult factory.

C_v VALUES (US-GPM @ 1 PSID)

| Valve Size (inches) | 2 | 2½ | 3 |
|---------------------|----|----|-----|
| C _v | 48 | 90 | 171 |



DOUBLE DOOR CHECK VALVES

INSTALLATION AND MAINTENANCE INSTRUCTIONS

VALVE LOCATION AND ORIENTATION IN PIPING

Check valves should be installed, if possible, a minimum of 6 pipe diameters from other line elements, i.e. elbows, pumps, valves, etc.

Horizontal Lines

- Valves installed in horizontal lines must be bolted in place with the hinge post in the vertical position, i.e. in such a manner that the hinge pin retainers are at the top and bottom of the installed valve, perpendicular to the flow.

Vertical Lines

- In the upward position, no special attention needs to be given to the hinge post position. The only exception being when mounted directly downstream of an elbow. In this case the hinge post should be mounted perpendicular to the outermost portion of the elbow. Consult factory for vertical down flow applications.

PRECAUTIONS

- Do not install Series WT check valves directly against another valve whereby the check valve discharges downstream directly into the valve.
- Do not install the valve whereby it directly discharges downstream into a tee or elbow fitting.
- Series WT check valves should not be used in severe pulsating services such as reciprocating compressor discharges.
- It is recommended that the check valves be installed a minimum of three pipe diameters downstream of a pump or compressor.

MAINTENANCE

Spence Series WT check valves are permanently lubricated and normally require no routine maintenance.

RECONDITIONING

IMPORTANT! PRIOR TO DISASSEMBLY, VALVE MUST FIRST BE ISOLATED FROM SYSTEM PRESSURE AND FLOW.

Disc & Shaft Removal

CAUTION! BEFORE ATTEMPTING THE FOLLOWING SHAFT EXTRACTION, BE SURE TO PRESS A HAND OVER THE DISC SPRING. FAILURE TO DO THIS MAY RESULT IN PERSONAL INJURY DUE TO THE SPRING "LAUNCHING" ITSELF UNEXPECTEDLY ONCE THE SHAFT IS PULLED FREE OF IT.

- After observing the above precaution, remove the valve from the pipeline and lay flat with open, body cavity side facing up. Remove pipe plugs from top and bottom of body with a wrench. Insert a punch and lightly tap the top of the shaft until it is accessible on the other side of the body. Pull shaft through body to remove. The internals of the valve are now ready to be cleaned and inspected.

REASSEMBLY

Use new replacement parts, as required and a liberal amount of general-purpose grease (such as Mystic JT-6) on seals and machined mating surfaces. Reinsert the disc into the body cavity with the shaft holes inline with top and bottom shaft port. Slide the shaft into the

body through the shaft opening on one side of the valve. Continue sliding the shaft through the disc, spring and remaining shaft port the opposite side of the body. Install pipe plugs into the body using a good industrial grade thread sealant compound.

WARNING: *This product operates in pipelines or with equipment that carries fluids and/or gasses at elevated temperatures and pressures. Caution should be taken to make sure that this equipment is installed correctly and inspected regularly. Caution should also be taken to protect personnel from fluid or gas leakage.*

NOTES:

DOUBLE DOOR
CHECK VALVES

