

Applications

- Liquid Service
- Process Industry
- Power Industry
- Chemical Industry
- Oil & Gas
- Metals & Mining
- Water & Waste Water
- Pulp & Paper
- Marine

Flanged Silent Check Valves

Pressures to 285 PSIG
Temperatures to 400°F

FEATURES

- Silent Non-slam Closure
- Flanged Body Style
- Metal to Metal Seats



MATERIALS

- Cast Iron Body; Bronze Disc
- Cast Steel Body; Stainless Steel Disc
- Stainless Steel Body; Stainless Steel Disc

END CONNECTIONS

- Flat Faced
- Raised Faced

SIZES

- 2" (20mm) up to 18" (600mm)

RATINGS

- ASME Class 125
- ASME Class 150
- ASME Class 250

FLANGED SILENT
CHECK VALVES



125FC SERIES CAST IRON FLANGED SILENT CHECK VALVES

Pressures to 200 PSIG (13.8 barg)
Temperatures to 300°F (149°C)

APPLICATIONS

- Liquid Service
- Process Industry
- Power Industry
- Chemical Industry
- Oil & Gas
- Pulp & Paper
- Metal & Mining
- Water & Waste

- ASME Class 125 rated check valve
- Designed to reduce surge and water hammer
- Silent, non-slam closure
- Center guided at both ends to prevent binding and cocking
- Flanged body style
- Bronze Metal to Metal Seats
- Designed to reduce Water Hammer

MODELS

- 125FCIB - Cast Iron Body, Bronze Seat and Disc

OPTIONS *(Consult factory)*

- Other Spring Material
- Heavier or Lighter Springs

APPLICABLE CODES

- Bodies in accordance with ASME B16.1
- API 598

Canadian Registraton - OC10274.5C

PRESSURE/TEMPERATURE CHART
ASME 16.1

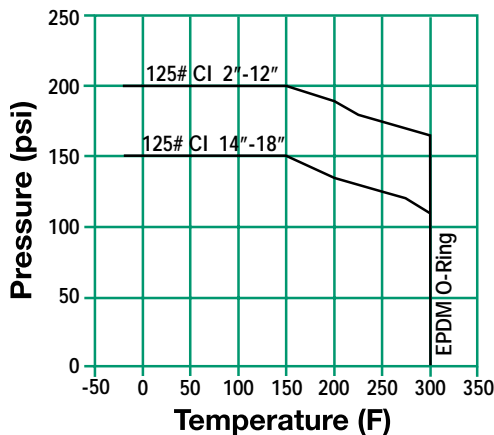

FLANGED SILENT CHECK VALVES

125FC Series Ordering Code

Inlet Size				Dash	Model								Seat	Dash	Spring
0	8	0	0	-	1	2	5	F	C	I	B	M	-	T	
1	2	3	4	5	6	7	8	9	10	11	12	13	14	15	

Inlet Size - Position 1 - 4

- 0200 - 2"
- 0250 - 2 1/2"
- 0300 - 3"
- 0400 - 4"
- 0500 - 5"
- 0600 - 6"
- 0800 - 8"
- 1000 - 10"
- 1200 - 12"
- 1400 - 14"
- 1600 - 16"
- 1800 - 18"

Dash - Position 5

Model - Position 6 - 12
125FCIB - CI Body, Bz Disc

Seat - Position 13
M - Metal

Dash - Position 14

Spring - Position 15
T - Stainless Steel



125FC SERIES CAST IRON FLANGED SILENT CHECK VALVES

SPECIFICATION

Check Valve shall be single disc design with Cast Iron Flanged body style designed to ASME B16.1. The check valve shall have a metal to metal seat with bronze seat and disc. The check valve shall be ASME Class 125 rated. The spring shall be 316SS. The check valve shall be SSI 125FC Cast Iron Series.

MATERIALS OF CONSTRUCTION

BodyA126-B Cast Iron
Discs.....B62 Bronze
SeatB62 Bronze
Spring316SS
O-RingEPDM

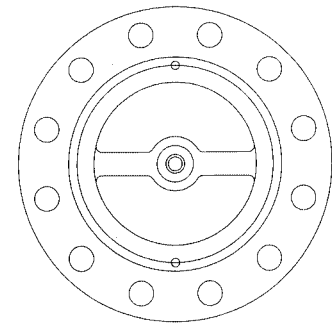

FRONT VIEW

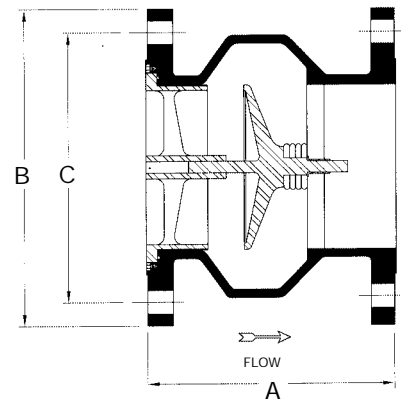

DIMENSIONS inches (mm) AND WEIGHTS pounds (kg)

Size	A	B	C	Weight
2 (50)	6 ¹ / ₈ (156)	6 (152)	4 ³ / ₄ (121)	21 (9.4)
2 ¹ / ₂ (65)	7 (178)	7 (178)	5 ¹ / ₂ (140)	31 (13.8)
3 (80)	7 ¹ / ₂ (191)	7 ¹ / ₂ (191)	6 (153)	37 (16.5)
4 (100)	8 ¹ / ₂ (216)	9 (229)	7 ¹ / ₂ (191)	62 (28)
5 (125)	9 ¹ / ₂ (241)	10 (254)	8 ¹ / ₂ (216)	80 (36)
6 (150)	10 ¹ / ₂ (267)	11 (280)	9 ¹ / ₂ (241)	106 (48)
8 (200)	13 ¹ / ₂ (343)	13 ¹ / ₂ (343)	11 ³ / ₄ (299)	175 (79)
10 (250)	16 ¹ / ₄ (413)	16 (406)	14 ¹ / ₄ (362)	267 (121)
12 (300)	20 ¹ / ₄ (515)	19 (483)	17 (431)	477 (216)
14 (350)	22 ³ / ₄ (580)	21 (533)	18 ³ / ₄ (477)	785 (356)
16 (400)	24 ³ / ₄ (629)	23 ¹ / ₂ (597)	21 ¹ / ₄ (540)	900 (408)
18 (450)	22 ¹ / ₂ (572)	25 (635)	22 ³ / ₄ (578)	1032 (468)

Dimensions shown are subject to change.
Contact factory for certified prints when required.

Connections: 2" to 18" Flanged FF

Seats: 2" to 18" Bronze

Cracking Pressure:
Horizontal Mounting - .3 psid
Vertical Mounting - .75 to 1.25 psid

FLANGED SILENT
CHECK VALVES

125FC SERIES

CAST IRON FLANGED SILENT CHECK VALVES

PRESSURE DROP VS FLOW RATE

(Sizes 2" - 18")

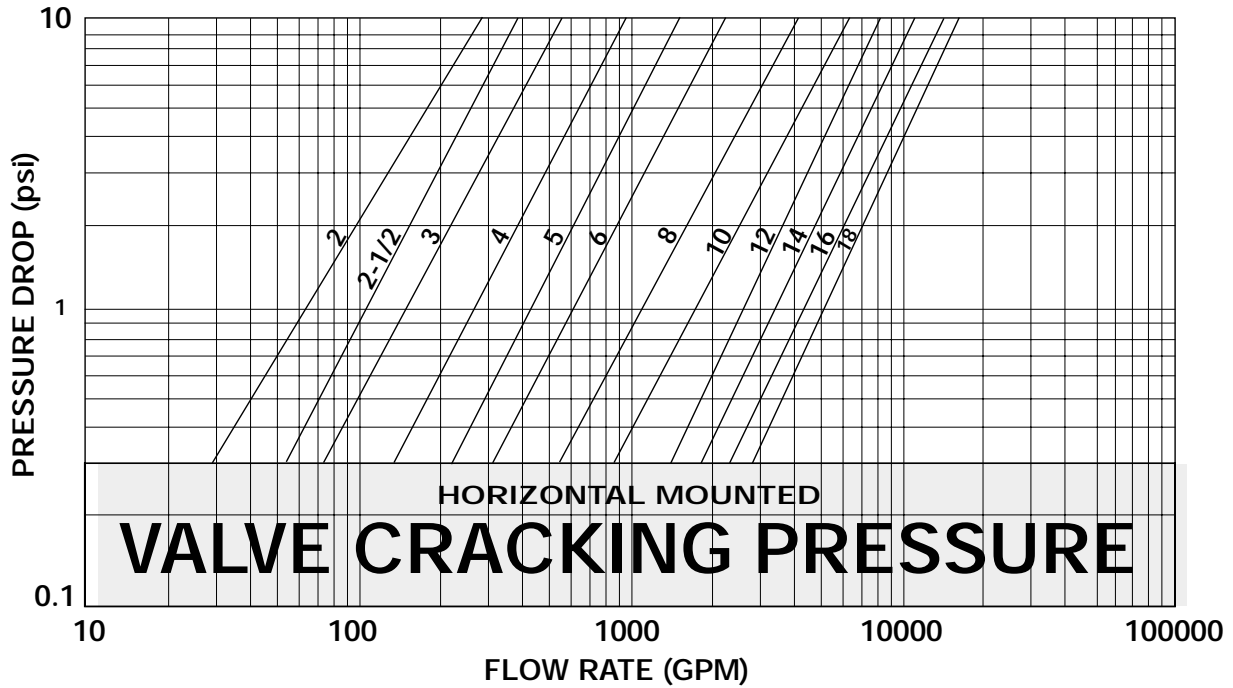

- (1) Pressure drop curves are based on water flow.
- (2) Valve cracking pressure is equal to or less than 0.3 psid when mounted horizontally.
- (3) Valve cracking pressure increases to between 0.75 and 1.25 psid when installed vertically with flow upwards.

Installation Note:

1. For correct installation and maintenance please see our I&M manual.
2. Vertical installation (downward flow) – Consult factory.
3. Always use Strainers in upstream piping.
4. Not recommended for Steam Service

Cv Values

Size (inches)	2	2½	3	4	5	6	8	10	12	14	16	18
Min Cv (@.3 PSID)	53	99	135	246	402	566	1004	1579	2556	3286	4199	5112
CV (@1 PSID)	63	105	148	265	430	605	1105	1700	2575	3350	4300	5225
Max Cv (@10 PSID)	89	120	174	300	474	696	1297	1992	2593	3479	4427	5376

FLANGED SILENT CHECK VALVES



NOTES:

FLANGED SILENT
CHECK VALVES



150FC SERIES CAST STEEL AND STAINLESS STEEL FLANGED SILENT CHECK VALVES

Pressures to 285 PSIG (19.7 barg)
Temperatures to 400°F (204°C)

- ASME Class 150 rated check valve
- Designed to reduce surge and water hammer
- Silent, non-slam closure
- Center guided at both ends to prevent binding and cocking
- Flanged body style
- Stainless Steel Metal to Metal Seats

APPLICATIONS

- Liquid Service
- Process Industry
- Power Industry
- Chemical Industry
- Oil & Gas
- Pulp & Paper
- Metal & Mining
- Water & Waste

MODELS

- 150FCCT - Cast Steel Body, Stainless Steel Seat and Disc
- 150FCTT - Stainless Steel Body, Stainless Steel Seat and Disc

OPTIONS *(Consult factory)*

- Other Spring Material
- Heavier or Lighter Springs

APPLICABLE CODES

- ASME Sec. VIII and B16.34 Bodies
- API 598

Canadian Registration - OC10274.5C

**PRESSURE/TEMPERATURE CHART
ASME 16.34**

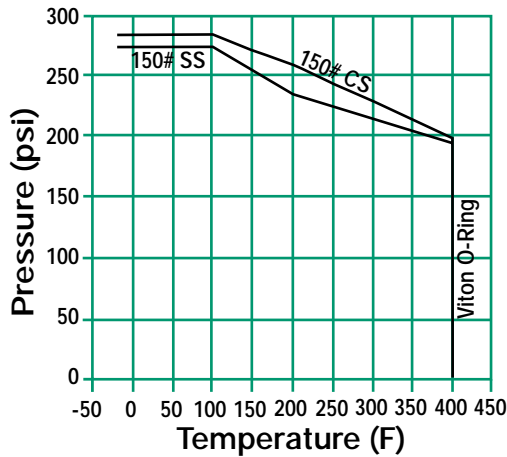

FLANGED SILENT
CHECK VALVES

150FC Series Ordering Code

Inlet Size				Dash	Model								Seat	Dash	Spring
0	4	0	0	-	1	5	0	F	C	T	T	M	-	T	
1	2	3	4	5	6	7	8	9	10	11	12	13	14	15	

Inlet Size* - Position 1 - 4
0200 - 2"
0250 - 2½"
0300 - 3"
0400 - 4"
0500 - 5"
0600 - 6"
0800 - 8"
1000 - 10"
1200 - 12"
1400 - 14"
1600 - 16"

Dash - Position 5
Model - Position 6 - 12 150FCCT - CS Body, SS Disc 150FCTT - SS Body, SS Disc
Seat - Position 13 M - Metal
Dash - Position 14
Spring - Position 15 T - Stainless Steel

* Cast Steel body 2" - 16"
Stainless Steel body 2" - 12"



150FC SERIES

CAST STEEL AND STAINLESS STEEL FLANGED SILENT CHECK VALVES

SPECIFICATION

Check Valve shall be single disc design with Cast Steel or Stainless Steel Flanged body style designed to ASME Sec. VIII and ASME B16.34. The check valve shall have a metal to metal seat with Stainless Steel seat and disc. The check valve shall be ASME Class 150 rated. The spring shall be 316SS. The check valve shall be SSI 150FC Cast Steel or Stainless Steel Series.

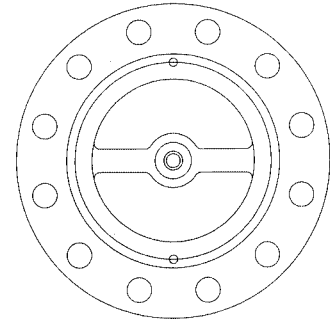

FRONT VIEW

MATERIALS OF CONSTRUCTION

Part	Cast Steel	Stainless Steel
Body	A216 WCB	A351 CF8M
Discs	A351 CF8M	A351 CF8M
Seat	A351 CF8M	A351 CF8M
Spring	316SS	316SS
O-Ring	Viton	Viton

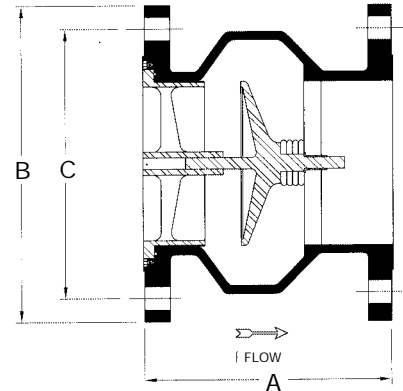

DIMENSIONS inches (mm) AND WEIGHTS pounds (kg)

Size	A	B	C	Weight
2 (50)	6 ¹ / ₄ (159)	6 (152)	4 ³ / ₄ (121)	15 (6.6)
2 ¹ / ₂ (65)	7 (178)	7 (178)	5 ¹ / ₂ (140)	21 (9.3)
3 (80)	7 ¹ / ₂ (191)	7 ¹ / ₂ (191)	6 (153)	26 (11.5)
4 (100)	8 ¹ / ₂ (216)	9 (229)	7 ¹ / ₂ (191)	48 (21.3)
5 (125)	9 ¹ / ₂ (242)	10 (254)	8 ¹ / ₂ (216)	61 (27.3)
6 (150)	10 ¹ / ₂ (267)	11 (280)	9 ¹ / ₂ (241)	76 (34.1)
8 (200)	12 (305)	13 ¹ / ₂ (343)	11 ³ / ₄ (299)	129 (58.4)
10 (250)	14 (356)	16 (406)	14 ¹ / ₄ (362)	183 (82.8)
12 (300)	18 (457)	19 (483)	17 (431)	344 (156)
14 * (350)	19 ¹ / ₂ (495)	21 (533)	18 ³ / ₄ (477)	433 (196)
16 * (400)	21 (533)	23 ¹ / ₂ (597)	21 ¹ / ₄ (540)	607 (275)

* 14" and 16" only available in Cast Steel body, contact factory for Stainless Body availability.

Dimensions are subject to change.
Consult factory for certified drawings when required.

Connections :
2" to 16" Cast Steel Body Flanged RF
2" to 12" Stainless Steel Body Flanged RF

Seats: All sizes - Stainless Steel

Cracking Pressure:
Horizontal Mounting - .3 psid
Vertical Mounting - .75 to 1.25 psid

FLANGED SILENT
CHECK VALVES

150FC SERIES

CAST STEEL & STAINLESS STEEL FLANGED SILENT CHECK VALVES

PRESSURE DROP VS FLOW RATE

(Sizes 2" - 16")

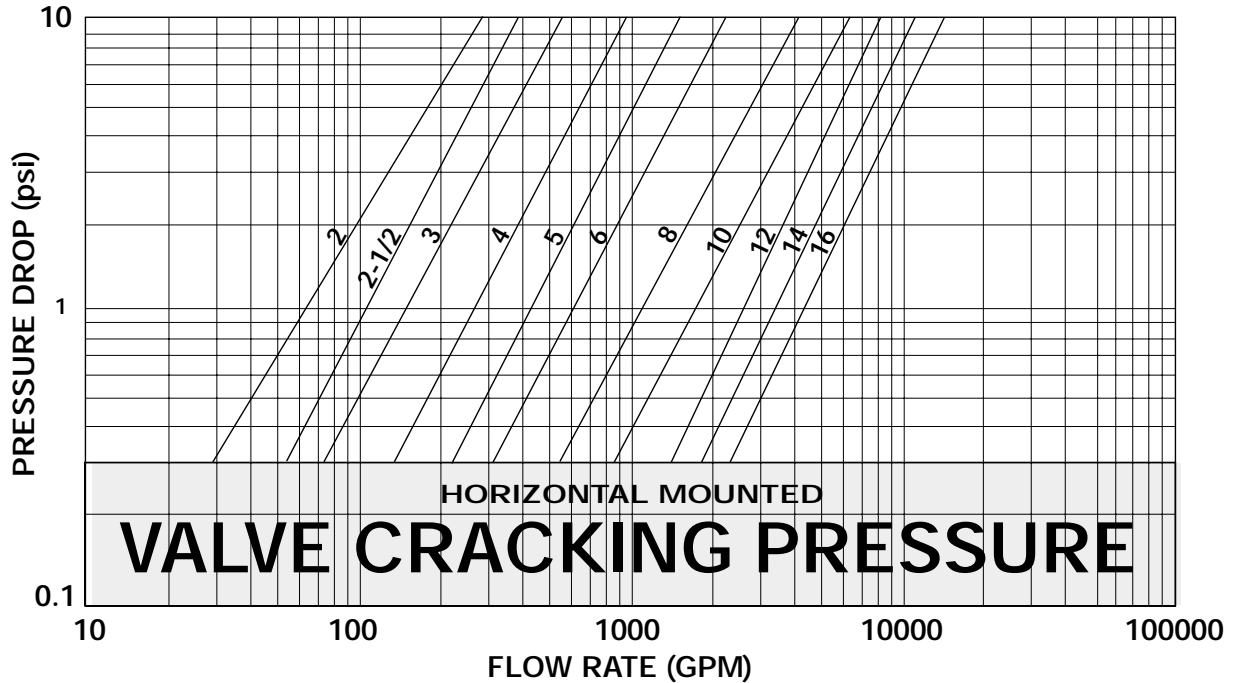

- (1) Pressure drop curves are based on water flow.
- (2) Valve cracking pressure is equal to or less than 0.3 psid when mounted horizontally.
- (3) Valve cracking pressure increases to between 0.75 and 1.25 psid when installed vertically with flow upwards.

Installation Note:

1. For correct installation and maintenance please see our I&M manual.
2. Vertical installation (downward flow) – Consult factory.
3. Always use Strainers in upstream piping.
4. Not recommended for Steam Service

Cv Values

Size (inches)	2	2½	3	4	5	6	8	10	12	14	16
Min Cv (@.3 PSID)	53	99	135	246	402	566	1004	1579	2556	3286	4199
Cv (@1 PSID)	63	105	148	265	430	605	1105	1700	2575	3350	4300
Max Cv (@10 PSID)	89	120	174	300	474	696	1297	1992	2593	3479	4427

NOTES:

FLANGED SILENT
CHECK VALVES



250FC SERIES CAST IRON FLANGED SILENT CHECK VALVES

Pressures to 400 PSI (27.6. barg)
Temperatures to 200°F (93°C)

APPLICATIONS

- Liquid Service
- Process Industry
- Power Industry
- Chemical Industry
- Oil & Gas
- Pulp & Paper
- Metal & Mining
- Water & Waste

- ASME Class 250 rated check valve
- Designed to reduce surge and water hammer
- Silent, non-slam closure
- Center guided at both ends to prevent binding and cocking
- Flanged body style
- Bronze Metal to Metal Seats
- Designed to reduce Water Hammer

MODELS

- 250FCIB - Cast Iron Body, Bronze Seat and Disc

OPTIONS *(Consult factory)*

- Other Spring Material
- Heavier or Lighter Springs

APPLICABLE CODES *(Designed in accordance with)*

- ASME B16.1

PRESSURE/TEMPERATURE CHART
ASME B16.1

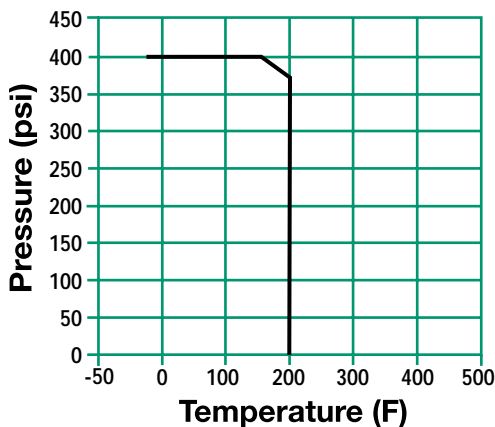

FLANGED SILENT CHECK VALVES

250FC Series Ordering Code

Inlet Size				Dash	Model								Seat	Dash	Spring
0	8	0	0	-	2	5	0	F	C	I	B	M	-	T	
1	2	3	4	5	6	7	8	9	10	11	12	13	14	15	

Inlet Size - Position 1 - 4
0250 - 2 1/2"
0300 - 3"
0400 - 4"
0500 - 5"
0600 - 6"
0800 - 8"
1000 - 10"
1200 - 12"

Dash - Position 5
Model - Position 6 - 12
250FCIB - CI Body, Bz Disc
Seat - Position 13
M - Metal
Dash - Position 14
Spring - Position 15
T - Stainless Steel



250FC SERIES CAST IRON FLANGED SILENT CHECK VALVES

SPECIFICATION

Check Valve shall be single disc design with Cast Iron Flanged body style designed to ASME B16.1. The check valve shall have a metal to metal seat with bronze seat and disc. The check valve shall be ASME Class 250 rated. The spring shall be 304SS. The check valve shall be SSI 250F Cast Iron Series.

MATERIALS OF CONSTRUCTION

BodyA126-A Cast Iron
Discs.....B62 Bronze
SeatB62 Bronze
Spring304SS
O-RingEPDM

DIMENSIONS inches (mm) AND WEIGHTS pounds (kg)

Size	A	B	C	Weight
2½ (65)	5½ (127)	5½ (127)	5½ (150)	30 (13.6)
3 (80)	6 (140)	8¼ (216)	6¾ (168)	36 (16.4)
4 (100)	7¼ (184)	10 (254)	7¾ (200)	59 (27)
5 (125)	8½ (216)	11 (280)	9¼ (235)	78 (36)
6 (150)	9¾ (248)	12½ (318)	10¾ (270)	103 (47)
8 (200)	12½ (318)	15 (381)	13 (331)	179 (82)
10 (250)	15½ (394)	17½ (445)	15¼ (388)	253 (115)
12 (300)	14¾ (362)	20½ (521)	17¾ (451)	401 (182)

Dimensions shown are subject to change.
Contact factory for certified prints when required.

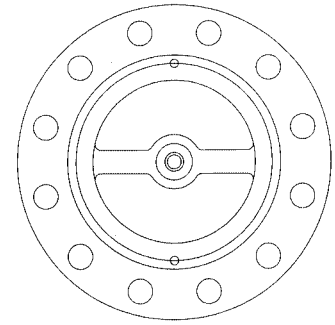

FRONT VIEW

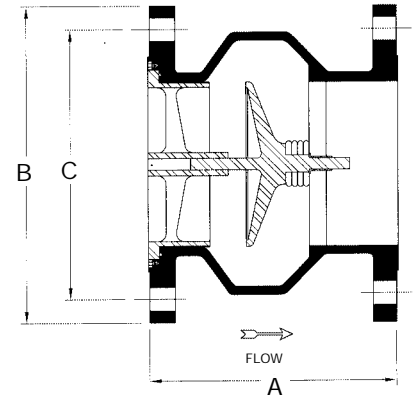

Connections: 2½" to 12" Flanged FF

Seats: 2½" to 12" Bronze

Cracking Pressure: .5 psid

FLANGED SILENT
CHECK VALVES

250FC SERIES

CAST IRON FLANGED SILENT CHECK VALVES

PRESSURE DROP VS FLOW RATE¹

(Sizes 2½" - 12")

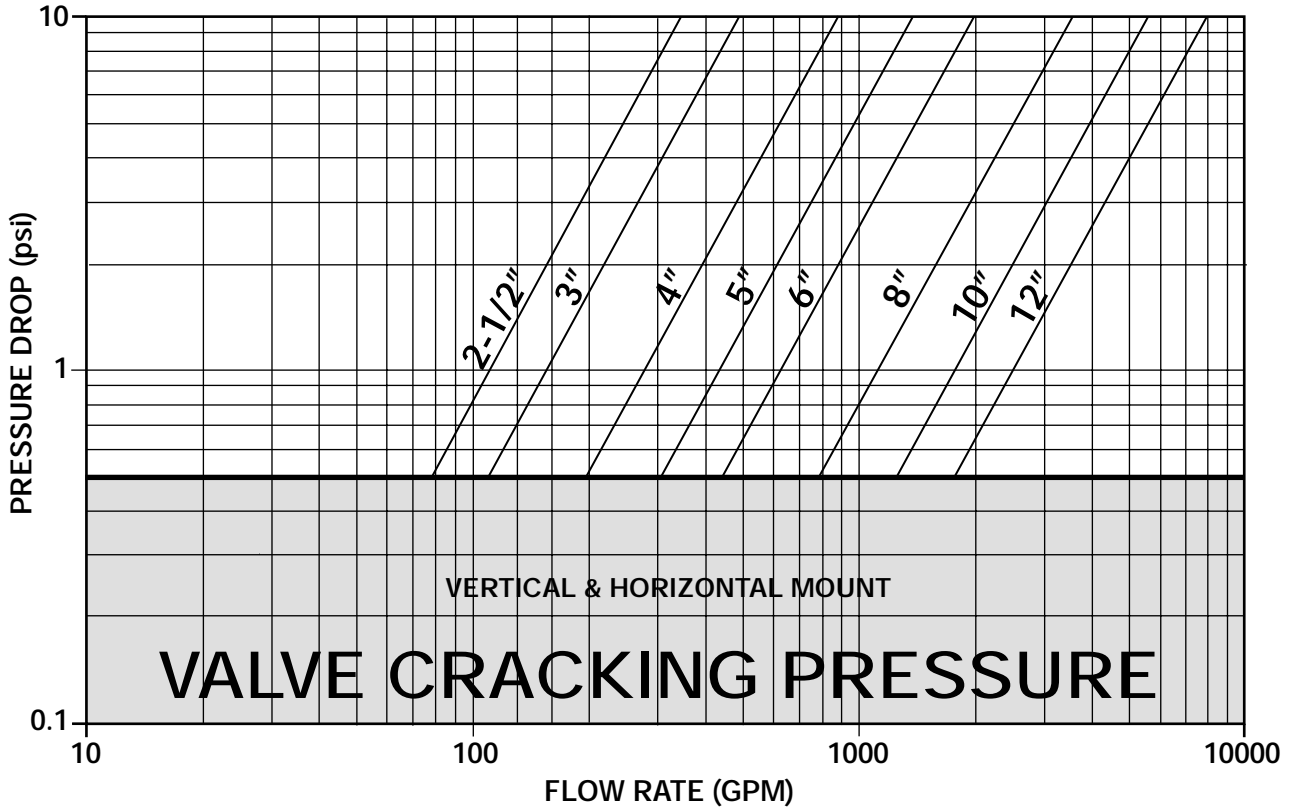

1. Pressure drop curves are based on water flow.
2. Valve cracking pressure is equal to or less than 0.5 psid when installed vertically and horizontally.

Installation Note

1. For correct installation and maintenance, please see our I&M manual.
2. Vertically installation (downward flow) – Consult factory
3. Always use Strainers in upstream piping.
4. Not recommended for Steam Service.

Cv Values

Size (inches)	2½	3	4	5	6	8	10	12
Min Cv (@.5 PSID)	78	110	197	308	442	788	1252	1768
Cv (@1 PSID)	110	155	278	435	625	1115	1770	2500
Max Cv (@10 PSID)	348	490	879	1376	1976	3526	5597	7906



FLANGED SILENT CHECK VALVES

INSTALLATION AND MAINTENANCE INSTRUCTIONS

Check valves should be installed, if possible, a minimum of 6 pipe diameters from other line elements, i.e. elbows, pipes, valves, etc.

CHECK VALVE INSTALLATION

- Valves may be installed upward vertically, horizontally, or at other angles. For vertical downward flow please consult with the factory.
- Install the valve with proper positioning of the flow arrow.
- Support and align adjacent piping and the valve
- Install lubricated flange bolts.
- Hand tighten, then torque the bolts using the cross-over flange bolt tightening method to load the bolts evenly, and eliminate concentrated stresses.
- Valves must be mounted to ASME flanges with conventional flat face or ring gaskets.
- Proper centering of the ring gaskets is important to prevent internal leakage.
- Never lift the valve by the bronze or stainless steel trim.
- Install a strainer in the piping.

PRECAUTIONS

- Do not install check valves directly against another valve whereby the check valve discharges downstream directly into the valve.
- Do not install the valve whereby it directly discharges downstream into a tee or elbow fitting.
- These valves are not suggested for installation in sewage ejector piping.
- Careful consideration should be given to the selection of valves for use in an air, steam, hot water and boiler feed systems. Consult our factory on these applications.
- Individuals performing removal and disassembly should be provided with suitable protection from possibly hazardous liquids.
- Prior to disassembly, valve must first be isolated from system pressure and flow.
- Upon disassembly ensure spring pressure is released slowly to prevent personal injury due to the spring "launching" itself unexpectedly.

WARNING: *This product operates in pipelines or with equipment that carries fluids and/or gasses at elevated temperatures and pressures. Caution should be taken to make sure that this equipment is installed correctly and inspected regularly. Caution should also be taken to protect personnel from fluid or gas leakage.*