

# MAIN VALVES

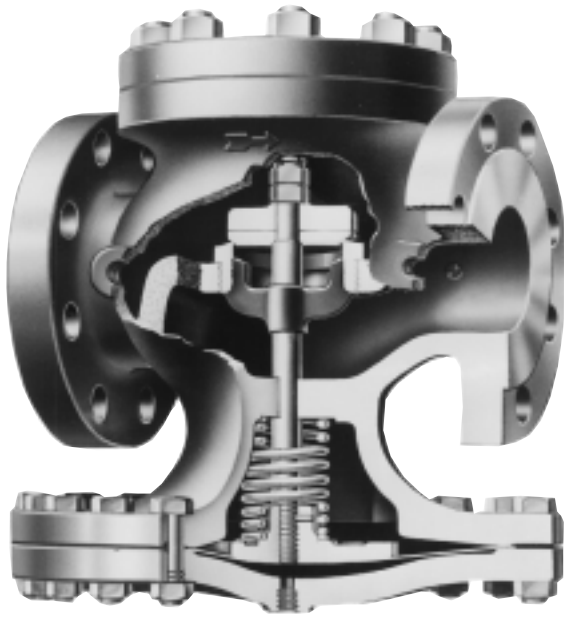

TYPE E MAIN VALVE

**APPLICATION DATA**

- Pressure Regulating for Steam Distribution
- Regulating for Process Control (Temperature or Pressure)
- Maintain Back Pressure or Differential Pressure
- For use with Self-contained, Pneumatic or Electronic Pilots
- Single Point or Multiple Use Applications
- Slow Start-up or Shutdown

SIZING INFO  
PAGE 108

**VALVE RATINGS**

Valve Ends ASME/ANSI	Pressure PSIG (bar)	Temperature °F (°C)
-------------------------	------------------------	------------------------

**CAST IRON**

Class 250 NPT	250 (17.2)	@ 450 (232)
B16.1 Class 125 Flanged	125 (8.6)	@ 450 (232)
B16.1 Class 250 Flanged	250 (17.2)	@ 450 (232)

**CAST STEEL**

B16.34 Class 300 NPT	300 (21.0)	@ 600 (315)†
B16.34 Class 150 Flanged	150 (10.3)	@ 500 (260)
B16.34 Class 300 Flanged	300 (21.0)	@ 600 (315)†
B16.34 Class 600 Flanged	600 (41.4)	@ 600 (315)†

†750°F (400°C) construction available on request.  
Other pressure/temperature ratings available; consult factory.  
Maximum downstream pressure is 300 psi.  
Canadian Registration # OC 0591.9C

*Installation Tip:* Add EZ Connections for ease of maintenance  
SEE PAGE 42

# TYPE E MAIN VALVE

SIZES 3/8" – 12"

PRESSURES to 600 PSIG at 750°F

- Normally Closed
- Single Seat
- Balanced Metal Diaphragms
- Protected Main Spring
- Fluid, Gas & Vapor Applications
- Multiple Trims for Precise Sizing
- ANSI/FCI 70-2 Class IV Shutoff
- Virtually Frictionless for Long Service Life
- Packless Construction
- Easy In-line Maintenance
- Wide Variety of Pilots for Many Applications
- Minimum Operating ΔP 10 psi (.7 bar)
- Lifetime Warranty against Wiredrawing of Seat & Disc\*

**OPTIONS**

- Composition Disc See Page 42
- Parabolic Disc
- Balanced Construction
- Integral Mount Pilot
- Insulcap Insulating Jacket
- Secoweld
- High Temperature Construction
- Dashpot
- Low ΔP (LP) Main Spring
- EZ Connections

**TYPICAL CONFIGURATIONS**

- PRESSURE REDUCING .....TYPE ED SERIES
- AIR ADJUSTED .....TYPE EA SERIES
- BACK PRESSURE .....TYPE EQ SERIES
- PUMP GOVERNOR .....TYPE EP SERIES
- LOAD ALLOCATING .....TYPE EFD
- AIR CONTROLLED .....TYPE EAP60
- ELECTRONIC SLOW START .....TYPE ED208D
- SOLENOID CONTROLLED .....TYPE EMD
- SOLENOID ACTUATED .....TYPE EM
- DIFFERENTIAL .....TYPE EN
- TEMPERATURE CONTROL .....TYPE ET SERIES

**RATED FLOW COEFFICIENTS (Cv)**

SEAT FACTOR	REGULATOR SIZE														
	3/8	1/2	3/4	1	1 1/4	1 1/2	2	2 1/2	3	4	5	6	8	10	12
Full	1.5	2.8	5.4	8.8	14.1	19.8	31	44	74	109	169	248	444	706	1113
Full 75 %	—	2.1	4.0	6.6	10.6	14.8	23.3	33	56	82	127	186	333	530	835
Full 50 %	—	1.4	2.7	4.4	7.0	9.9	15.5	22	37	55	85	124	222	353	557
Normal	.65	1.5	4.8	7.5	10.4	14.6	17.6	24	43	78	115	151	249	377	631
Normal 75 %	—	—	—	—	—	—	—	18	33	59	87	114	187	283	474
Normal 50 %	—	—	—	—	—	—	—	12	22	39	58	76	125	189	316

# TYPE E MAIN VALVE

## SPECIFICATION

The valve shall be self-operated, external pilot type, single seated, metal diaphragm actuated, normally closed design. The valve will function quickly and shut tight on dead end service. Internal parts including seats, discs, stems and diaphragms shall be of stainless steel. There shall be no springs in the steam space and no stuffing box. The valve shall be easy to maintain with all parts accessible without removal from the line.

## MATERIALS OF CONSTRUCTION

Body, Cast Iron .....ASTM A126 Cl. B  
 Body, Cast Bronze .....ASTM B61 UNS C92200  
 Body, Cast Steel .....ASTM A216 WCB  
 Stem .....303 St. Stl. ASTM A582  
 Disc 3/4 - 5" .....420 St. Stl. ASTM A743 CA-40  
 Disc 6 - 12" .....304 St. Stl. ASTM A167/A240  
 Seat 3/4 - 5" .....420 St. Stl. ASTM A743 CA-40  
 Seat 6 - 12" .....316 St. Stl. ASTM A743-79 CF-8M  
 Gasket .....Non-asbestos  
 Diaphragm .....Stainless Steel MIL-S-5059C  
 Spring .....Steel

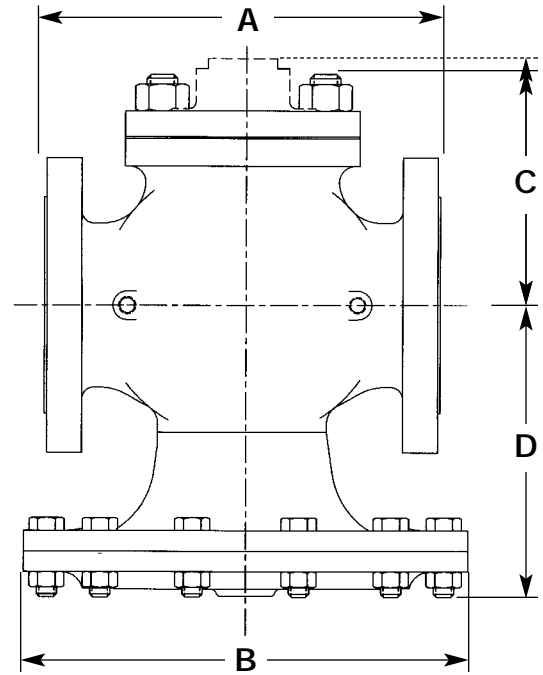

TYPE E MAIN VALVE

FITTINGS ON  
PAGE 46

TYPE E  
MAIN VALVE

## DIMENSIONS inches (mm) AND WEIGHTS pounds (kg)

SIZE	FACE TO FACE DIMENSIONS					B	C					D*	APPROX. WT.			
	A						Std. Mount		Integral Mount				ANSI NPT	ANSI 125,150	ANSI 250,300	ANSI 600
	ANSI NPT	ANSI 125,150	ANSI 250	ANSI 300	ANSI 600		ANSI 600	Cl & Brz. All	Steel	Steel 600						
3/8 (10)	4 3/8 (111)	—	—	—	—	5 7/8 (149)	2 3/4 (70)	—	3 1/2 (89)	3 1/2 (89)	—	5 1/4 (133)	14 (6)	—	—	—
1/2 (12)	4 3/8 (111)	—	—	—	6 (152)	5 7/8 (149)	2 3/4 (70)	2 3/4 (70)	3 1/2 (89)	3 1/2 (89)	3 5/8 (92)	5 1/4 (133)	14 (6)	—	—	20 (9.1)
3/4 (19)	4 3/8 (111)	—	—	—	6 3/8 (162)	6 1/2 (165)	2 7/8 (73)	3 3/8 (98)	3 5/8 (92)	3 3/4 (95)	4 1/2 (114)	5 1/2 (140)	18 (8)	—	—	28 (13)
1 (25)	5 3/8 (137)	5 1/2 (140)	6 (152)	6 1/2 (165)	6 1/2 (165)	7 (178)	3 5/8 (92)	4 1/4 (108)	4 3/8 (111)	4 3/8 (111)	4 3/4 (121)	6 1/4 (159)	23 (10)	26 (12)	31 (14)	32 (15)
1 1/4 (32)	6 1/2 (165)	6 3/4 (171)	7 1/4 (184)	7 7/8 (200)	7 7/8 (200)	7 7/8 (200)	4 1/8 (105)	4 5/8 (117)	4 (102)	4 5/8 (117)	5 (127)	6 1/2 (165)	33 (15)	37 (17)	41 (19)	45 (20)
1 1/2 (38)	7 1/4 (184)	6 7/8 (175)	7 3/8 (187)	8 (203)	8 (203)	8 3/4 (222)	4 3/8 (111)	5 1/8 (130)	4 3/8 (111)	5 (127)	—	7 7/8 (181)	43 (20)	47 (21)	55 (25)	58 (26)
2 (51)	7 1/2 (191)	8 1/2 (216)	9 (229)	10 1/4 (260)	10 1/4 (260)	9 7/8 (251)	5 1/4 (133)	5 3/4 (146)	5 (127)	5 5/8 (143)	5 3/4 (146)	7 5/8 (194)	62 (28)	73 (33)	78 (35)	83 (38)
2 1/2 (64)	—	9 3/8 (238)	10 (254)	11 1/4 (286)	11 1/4 (286)	10 7/8 (276)	5 3/4 (146)	7 7/8 (200)	5 1/2 (140)	6 (152)	8 1/4 (210)	8 3/8 (213)	—	95 (43)	100 (45)	130 (59)
3 (76)	—	10 (254)	10 3/4 (273)	12 1/4 (311)	12 1/4 (311)	11 3/4 (298)	6 5/8 (168)	9 1/8 (232)	6 3/8 (162)	7 1/8 (181)	—	9 1/4 (235)	—	125 (57)	140 (64)	175 (80)
4 (102)	—	11 7/8 (302)	12 1/2 (318)	12 1/2 (318)	14 1/2 (368)	14 3/4 (375)	7 5/8 (194)	10 5/8 (270)	7 1/4 (184)	8 (203)	—	11 7/8 (302)	—	210 (95)	230 (105)	310 (141)
5 (127)	—	13 5/8 (346)	14 1/2 (368)	14 1/2 (368)	16 1/2 (419)	16 7/8 (429)	8 1/2 (216)	12 1/2 (318)	8 1/8 (206)	8 1/2 (216)	—	12 1/2 (318)	—	295 (134)	310 (141)	490 (223)
6 (152)	—	15 1/8 (384)	16 (406)	16 (406)	17 3/8 (441)	19 3/4 (502)	10 (254)	13 3/4 (349)	9 1/2 (241)	9 1/2 (241)	13 5/8 (346)	14 1/8 (359)	—	420 (191)	470 (214)	655 (298)
8 (203)	—	19 (483)	20 (508)	20 (508)	21 5/8 (549)	22 1/2 (572)	11 1/2 (292)	15 3/8 (391)	11 1/4 (286)	11 3/4 (298)	—	17 1/4 (438)	—	700 (318)	710 (323)	1070 (486)
10 (254)	—	23 5/8 (600)	25 (635)	25 (635)	—	28 (711)	13 3/4 (349)	—	—	—	—	23 3/8 (594)	—	1240 (563)	1300 (591)	—
12 (305)	—	26 1/2 (673)	28 (711)	28 (711)	—	33 (838)	15 7/8 (403)	—	—	—	—	25 1/4 (641)	—	2060 (936)	2140 (972)	—

\*Add 65% to D dimension for stem removal clearance.

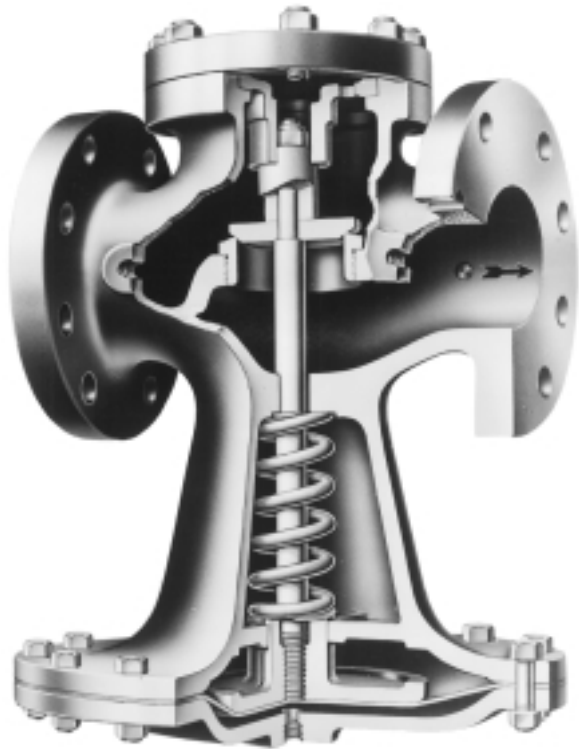

**TYPE E2 MAIN VALVE**

# TYPE E2 MAIN VALVE

## LOW PRESSURE LOW DIFFERENTIAL

SIZES 3/4" – 12"  
PRESSURES to 15 PSIG at 250°F

- Normally Closed
- Single Seat
- Hycar Diaphragm
- Protected Main Spring
- Gas & Steam Applications
- Accurate Regulation Unaffected by Service Conditions
- ANSI/FCI 70-2 Class IV Shutoff
- Virtually Frictionless for Long Service Life
- Packless Construction
- Easy In-line Maintenance
- Wide Variety of Pilots for Many Applications
- Minimum Operating  $\Delta P$  3 psi (.2 bar)
- Lifetime Warranty against Wiredrawing of Seat & Disc \*

### APPLICATION DATA

- Pressure Regulating for Steam Distribution
- Regulating for Process Control (Temperature or Pressure)
- Maintain Back Pressure or Differential Pressure
- For use with Self-contained, Pneumatic or Electronic Pilots
- Single Point or Multiple Use Applications
- Slow Start-up or Shutdown

### VALVE RATINGS

Valve Ends ASME/ANSI	Pressure PSIG (bar)	Temperature °F (°C)
<b>CAST IRON</b>		
B16.4 Class 250 NPT	15 (1.03)	250°F (121°C)
B16.1 Class 125 Flanged	15 (1.03)	250°F (121°C)

Canadian Registration # OC 0591.9C

*Installation Tip:* Add EZ Connections for ease of maintenance  
SEE PAGE 42

SIZING INFO  
PAGE 108

### OPTIONS *See page 42*

- Composition Disc for liquid, air or gas service
- Insulcap Insulating Jacket
- Integral Mount Pilot
- EZ Connections

### TYPICAL CONFIGURATIONS

- PRESSURE REDUCING .....TYPE E2D
- AIR ADJUSTED .....TYPE E2A SERIES
- BACK PRESSURE .....TYPE E2Q
- LOAD ALLOCATING .....TYPE E2FD
- AIR CONTROLLED .....TYPE E2AP60
- ELECTRONIC SLOW START .....TYPE E2D208D
- SOLENOID CONTROLLED .....TYPE E2MD
- SOLENOID ACTUATED .....TYPE E2M
- DIFFERENTIAL .....TYPE E2N
- TEMPERATURE CONTROL .....TYPE E2T14
- TEMP. & PRESSURE CONTROL .....TYPE E2T134

### RATED FLOW COEFFICIENTS (Cv)

SEAT FACTOR	REGULATOR SIZE												
	3/4	1	1 1/4	1 1/2	2	2 1/2	3	4	5	6	8	10	12
Full	7.6	11.7	18.9	27.4	44	68	96	143	202	255	465	748	1118
70%-75%	—	8.8	13.2	19.2	30.8	47.6	67.2	100	141	178	—	—	—
45%	—	—	—	12.3	—	30.6	—	64.4	—	11.4	—	336	—

\* When installed according to factory specifications.

# TYPE E2 MAIN VALVE

## SPECIFICATION

The valve shall be self-operated, external pilot type, single seated, hycar diaphragm actuated, normally closed design. The valve will function quickly and shut tight on dead end service. Internal parts including seats, discs and stems shall be of stainless steel. There shall be no springs in the steam flow path and no stuffing box. The valve shall be easy to maintain with all parts accessible without removal from the line.

## MATERIALS OF CONSTRUCTION

Body, Cast Iron .....ASTM A126 Cl. B  
 Body, Cast Bronze .....ASTM B61-80 61UNSC 92200  
 Stem .....303 St. Stl. ASTM A582  
 Disc 3/4 - 2" .....420 St. Stl ASTM A743 CA-40  
 Disc 2-1/2 - 12" .....304 St. Stl. ASTM A167/A240  
 Seat .....420 St. Stl. ASTM A743 CA-40  
 Gasket .....Non-asbestos  
 Diaphragm .....Hycar  
 Spring .....Steel

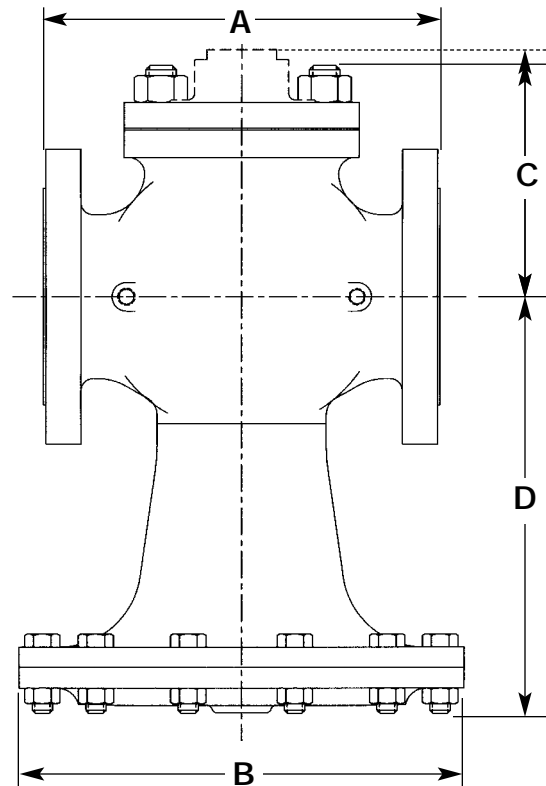

TYPE E2 MAIN VALVE

FITTINGS ON  
PAGE 46

**DIMENSIONS** inches (mm), **WEIGHTS** pounds (kg)

SIZE	A		OTHER DIMENSIONS				APPROX. WT.	
	CI, BRZ ANSI NPT	CI ANSI 125	B	C		D*	CI, BRZ ANSI NPT	CI ANSI 125
				Std. Mount	Integral Mount			
3/4 (19)	4 3/4 (121)	—	8 (203)	2 7/8 (73)	3 5/8 (92)	7 3/4 (197)	18 (8)	—
1 (25)	5 3/8 (137)	5 1/2 (140)	8 (203)	3 3/8 (92)	4 3/8 (111)	8 1/8 (206)	19 (9)	21 (10)
1 1/4 (32)	6 1/2 (165)	6 3/4 (171)	9 (229)	4 1/8 (105)	4 (101)	8 1/4 (210)	30 (14)	33 (15)
1 1/2 (38)	7 1/4 (184)	6 7/8 (175)	9 3/4 (248)	4 3/8 (111)	4 1/2 (118)	8 3/4 (222)	36 (16)	40 (18)
2 (51)	7 1/2 (191)	8 1/2 (216)	10 1/2 (267)	5 1/4 (133)	5 (127)	10 (254)	50 (23)	57 (26)
2 1/2 (64)	—	9 3/8 (238)	10 1/2 (267)	5 3/4 (146)	5 3/8 (136)	11 1/2 (292)	—	70 (32)
3 (76)	—	10 (254)	11 1/4 (286)	6 5/8 (168)	6 3/8 (162)	12 3/4 (324)	—	98 (45)
4 (102)	—	11 7/8 (302)	13 1/2 (343)	6 3/4 (171)	6 5/8 (168)	13 5/8 (346)	—	135 (61)
5 (127)	—	13 5/8 (346)	14 1/4 (362)	7 1/2 (191)	7 3/8 (187)	15 (381)	—	185 (84)
6 (152)	—	15 1/8 (384)	16 (406)	7 7/8 (200)	7 (178)	16 5/8 (422)	—	250 (114)
8 (203)	—	19 (483)	20 (508)	9 1/2 (241)	9 1/4 (235)	19 7/8 (505)	—	1210 (550)
10 (254)	—	23 5/8 (600)	24 (610)	10 7/8 (276)	—	23 7/8 (606)	—	690 (314)
12 (305)	—	26 1/2 (673)	28 (711)	12 3/4 (324)	—	27 1/8 (689)	—	1060 (482)

\*Add 55% to D dimension for stem removal clearance.



TYPE E5 MAIN VALVE

# TYPE E5 MAIN VALVE

## HIGH PRESSURE-HIGH LIFT LOW DIFFERENTIAL

SIZES 3/4" – 12"  
PRESSURES to 300 PSIG at 600°F

- Normally Closed
- Single Seat
- Balanced Hycar Diaphragm
- Protected Main Spring
- Long Main Spring Operates on 5 psi Minimum Differential
- Internal & External Condensation Chambers
- Fluid, Gas & Vapor Applications
- Accurate Regulation Unaffected by Service Conditions
- ANSI/FCI 70-2 Class IV Shutoff
- Virtually Frictionless for Long Service Life
- Packless Construction
- Easy In-line Maintenance
- Wide Variety of Pilots for Many Applications
- Lifetime Warranty against Wiredrawing of Seat & Disc \*

### APPLICATION DATA

- Pressure Regulating for Steam Distribution
- High Pressure/Low Differential Pressure Regulating
- Fluid Regulation
- For use with Self-contained, Pneumatic or Electronic Pilots
- Slow Start-up or Shutdown

SIZING INFO  
PAGE 108

### VALVE RATINGS

Valve Ends ASME/ANSI	Pressure PSIG (bar)	Temperature °F (°C)
-------------------------	------------------------	------------------------

#### CAST IRON

Class 250 NPT	250 (17.2) @	450 (232)
B16.1 Class 125 Flanged	125 (8.6) @	450 (232)
B16.1 Class 250 Flanged	250 (17.2) @	450 (232)

#### CAST STEEL

B16.34 Class 300 NPT	300 (21.0) @	600 (315)
B16.34 Class 150 Flanged	150 (10.3) @	500 (260)
B16.34 Class 300 Flanged	300 (21.0) @	600 (315)

Other pressure/temperature ratings available; consult factory.

Maximum downstream pressure is 300 psi.

Canadian Registration # OC 0591.9C

*Installation Tip:* Add EZ Connections for ease of maintenance  
SEE PAGE 42

### OPTIONS *See page 42*

- Composition Disc for liquid, air or gas service
- Balanced Construction
- Integral Mount Pilot
- Secoweld
- EZ Connections

### TYPICAL CONFIGURATIONS

PRESSURE REDUCING	.....TYPE E5D
AIR ADJUSTED	.....TYPE E5A
BACK PRESSURE	.....TYPE E5Q
PUMP GOVERNOR	.....TYPE E5P
LOAD ALLOCATING	.....TYPE E5FD
AIR CONTROLLED	.....TYPE E5AP60
ELECTRONIC SLOW START	.....TYPE E5D208D
SOLENOID CONTROLLED	.....TYPE E5MD
SOLENOID ACTUATED	.....TYPE E5M
DIFFERENTIAL	.....TYPE E5N
TEMPERATURE CONTROL	.....TYPE E5T

### RATED FLOW COEFFICIENTS (Cv)

SEAT FACTOR	REGULATOR SIZE													
	3/4	1	1 1/4	1 1/2	2	2 1/2	3	4	5	6	8	10	12	
Full	7.6	11.7	18.9	27.4	43	67	95	159	258	350	665	1018	1611	
Normal	5.7	10.0	13.4	19.8	25	35	59	120	176	228	366	525	952	

\* When installed according to factory specifications.

# TYPE E5 MAIN VALVE

## SPECIFICATION

The valve shall be self-operated, external pilot type, single seated, diaphragm actuated, normally closed design. The valve will function quickly and shut tight on dead end service. Internal parts including seats, discs and stems shall be of stainless steel. The diaphragm shall be a balanced Hycar material for high lift. There shall be an external condensation chamber supplied. The main valve spring shall operate on a 5 psi minimum differential. There shall be no springs in the steam flow path and no stuffing box. The valve shall be easy to maintain with all parts accessible without removal from the line.

## MATERIALS OF CONSTRUCTION

Body, Cast Iron .....ASTM A126 Cl. B  
 Body, Cast Steel .....ASTM A216 WCB  
 Stem .....303 St. Stl. ASTM A582  
 Disc 3/4 - 5" .....420 St. Stl. ASTM A582 Cond A  
 Disc 6 - 12" .....304 St. Stl. ASTM A167/A240  
 Seat 3/4 - 5" .....420 St. Stl. ASTM A582 Cond A  
 Seat 6 - 12" .....316 St. Stl. ASTM A743 CF-8M  
 Gasket .....Non-asbestos  
 Diaphragm .....Hycar  
 Spring .....Steel

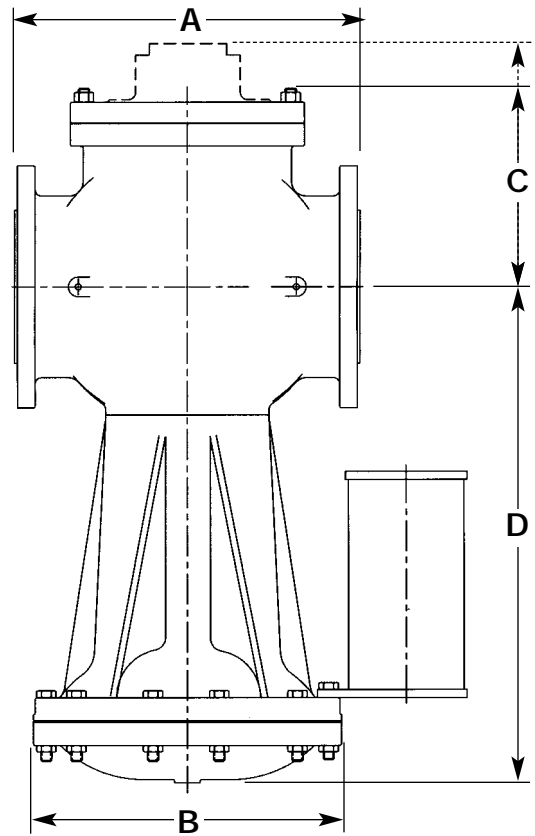

TYPE E5  
MAIN VALVE

TYPE E5 MAIN VALVE

FITTINGS ON  
PAGE 46

### DIMENSIONS inches (mm) AND WEIGHTS pounds (kg)

SIZE	A			B	C			D*		APPROX. WT				
	ANSI NPT	ANSI 125	ANSI 250		Std. Mount	Integral Mount		ANSI 125	SCR 250	Iron, Brz. Stl. ANSI NPT	Iron		Steel	
						Cl	Stl.				ANSI 125	ANSI 250	ANSI 150	ANSI 300
3/4 (19)	4 3/4 (111)	—	—	6 7/8 (175)	2 7/8 (73)	3 5/8 (92)	3 1/2 (89)	11 1/4 (286)	11 1/4 (286)	23 (10)	—	—	—	—
1 (25)	5 3/8 (137)	5 1/2 (140)	6 (152)	6 7/8 (175)	3 5/8 (92)	4 3/8 (111)	4 3/8 (111)	11 5/8 (295)	11 5/8 (295)	24 (11)	30 (14)	33 (15)	35 (16)	39 (18)
1 1/4 (32)	6 1/2 (165)	6 3/4 (171)	7 1/4 (184)	9 1/8 (232)	4 1/8 (105)	4 (102)	4 5/8 (117)	13 1/2 (343)	13 1/2 (343)	49 (22)	46 (21)	49 (22)	58 (26)	63 (29)
1 1/2 (38)	7 1/4 (184)	6 7/8 (175)	7 3/8 (187)	9 1/8 (232)	4 3/8 (111)	4 1/2 (114)	5 (127)	13 5/8 (346)	13 5/8 (346)	53 (24)	58 (26)	68 (31)	67 (30)	74 (34)
2 (51)	7 1/2 (191)	8 1/2 (216)	9 (229)	11 1/8 (283)	5 1/4 (133)	5 (127)	5 5/8 (143)	16 1/4 (413)	16 1/4 (413)	84 (38)	90 (41)	97 (44)	113 (51)	120 (55)
2 1/2 (64)	—	9 3/8 (238)	10 (254)	11 1/8 (283)	5 3/4 (146)	5 3/8 (137)	6 (152)	16 1/2 (419)	16 1/2 (419)	—	97 (44)	112 (51)	130 (59)	135 (61)
3 (76)	—	10 (254)	10 3/4 (273)	13 1/2 (343)	6 5/8 (168)	6 3/8 (162)	7 (178)	19 1/4 (489)	19 1/4 (489)	—	148 (67)	170 (77)	210 (95)	226 (103)
4 (102)	—	11 7/8 (302)	12 1/2 (318)	13 1/2 (343)	7 5/8 (194)	6 5/8 (168)	8 (203)	18 3/8 (467)	23 3/8 (594)	—	208 (95)	293 (133)	307 (139)	330 (150)
5 (127)	—	13 5/8 (346)	14 1/2 (368)	13 1/2 (343)	8 1/2 (216)	7 3/8 (187)	8 3/4 (222)	18 3/4 (476)	23 3/4 (603)	—	240 (109)	333 (151)	335 (152)	366 (166)
6 (152)	—	15 1/8 (384)	16 (406)	16 3/4 (425)	10 (254)	7 (178)	—	23 1/2 (597)	27 3/8 (695)	—	348 (158)	616 (280)	560 (254)	503 (274)
8 (203)	—	19 (483)	20 (508)	16 3/4 (425)	11 1/2 (292)	9 1/4 (235)	—	23 3/4 (603)	29 5/8 (752)	—	650 (295)	814 (370)	795 (361)	862 (392)
10 (254)	—	23 5/8 (600)	25 (635)	20 (508)	13 3/4 (349)	—	—	30 3/4 (781)	35 3/8 (899)	—	910 (414)	1130 (513)	1345 (611)	1420 (645)
12 (305)	—	26 1/2 (673)	28 (711)	24 3/4 (629)	15 7/8 (403)	—	—	39 3/4 (1010)	39 3/4 (1010)	—	1580 (718)	1920 (872)	1990 (904)	2160 (982)



TYPE E6 MAIN VALVE

# TYPE E6 MAIN VALVE

## HIGH PRESSURE-HIGH LIFT COLD SERVICE

SIZES 3/4" – 12"  
PRESSURES to 250 PSIG at 200°F

- Normally Closed
- Single Seat
- Balanced Hycar Diaphragm
- Protected Main Spring
- Composition Disc for Tight Shutoff
- Air & Gas Applications
- Accurate Regulation Unaffected by Service Conditions
- ANSI/FCI 70-2 Class VI Shutoff
- Virtually Frictionless for Long Service Life
- Packless Construction
- Easy In-line Maintenance
- Wide Variety of Pilots for Many Applications

### APPLICATION DATA

- Pressure Regulating for Compressed Air Distribution
- Pressure Regulating for Gas Service
- Maintain Back Pressure or Differential Pressure
- For use with Self-contained, Pneumatic or Electronic Pilots
- Single Point or Multiple Use Applications
- Slow Start-up or Shutdown

### VALVE RATINGS

Valve Ends ASME/ANSI	Pressure PSIG (bar)	Temperature °F (°C)
-------------------------	------------------------	------------------------

#### CAST IRON

B16.4 Class 250 NPT	250 (17.2)	@ 200 (93)
B16.1 Class 125 Flanged	125 (8.6)	@ 200 (93)

Other pressure/temperature ratings available; consult factory.

Canadian Registration # OC 0591.9C

*Installation Tip:* Add EZ Connections for ease of maintenance  
SEE PAGE 42

SIZING INFO  
PAGE 108

### OPTIONS *See page 42*

- Dashpot for Water Service
- Integral Mount Pilot
- Insulcap Insulating Jacket
- Balanced Construction
- EZ Connections

### TYPICAL CONFIGURATIONS

PRESSURE REDUCING	.....TYPE E6D
AIR ADJUSTED	.....TYPE E6A
BACK PRESSURE	.....TYPE E6Q
PUMP GOVERNOR	.....TYPE E6P
LOAD ALLOCATING	.....TYPE E6FD
AIR CONTROLLED	.....TYPE E6AP60
ELECTRONIC SLOW START	.....TYPE E6D208D
SOLENOID CONTROLLED	.....TYPE E6MD
SOLENOID ACTUATED	.....TYPE E6M
DIFFERENTIAL	.....TYPE E6N
TEMPERATURE CONTROL	.....TYPE E6T

### RATED FLOW COEFFICIENTS (Cv)

SEAT FACTOR	REGULATOR SIZE												
	3/4	1	1 1/4	1 1/2	2	2 1/2	3	4	5	6	8	10	12
Full	7.6	11.7	18.9	27.4	43	67	95	159	258	350	665	1018	1611
Normal	5.7	10.0	13.4	19.8	25	35	59	120	176	228	366	525	952

# TYPE E6 MAIN VALVE

## SPECIFICATION

The valve shall be self-operated, external pilot type, single seated, composition disc, hycar diaphragm actuated, normally closed design. The valve will function quickly and shut tight on dead end service. Seats and stems shall be of stainless steel. There shall be no springs in the flow space and no stuffing box. The valve shall be easy to maintain with all parts accessible without removal from the line.

## MATERIALS OF CONSTRUCTION

Body, Cast Iron .....ASTM A126 Cl. B  
 Body, Cast Bronze .....ASTM B61 UNS C92200  
 Stem .....303 St. Stl. ASTM A582  
 Disc .....Hycar Comp.  
 Seat 3/4 - 5" .....420 St. Stl. ASTM 473 CA-40  
 Seat 6 - 8" .....316 St. Stl. ASTM A743 CF-8M  
 Gasket .....Non-asbestos  
 Diaphragm .....Hycar  
 Spring .....Steel  
 Disc Holder .....ASTM B16 UNS C36000

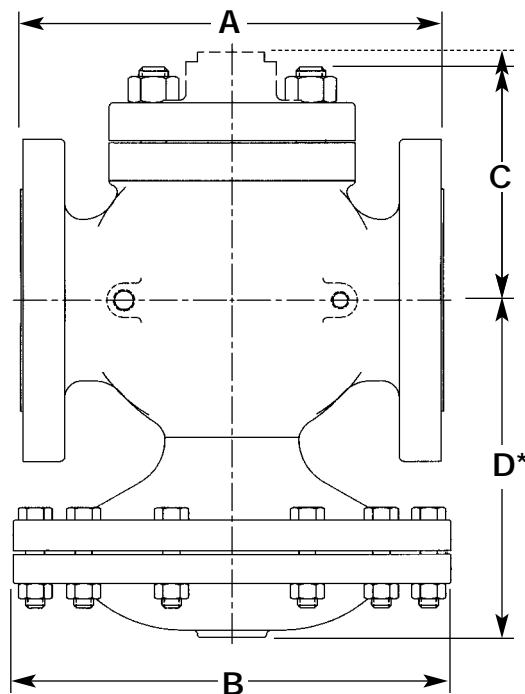

TYPE E6  
MAIN VALVE

TYPE E6 MAIN VALVE

FITTINGS ON  
PAGE 46

### DIMENSIONS inches (mm) AND WEIGHTS pounds (kg)

SIZE	DIMENSIONS							APPROX. WT.		
	A			B	C		D*	ANSI NPT	ANSI 125	ANSI 250
	ANSI NPT	ANSI 125	ANSI 250		Std. Mount	Integral Mount				
3/4 (19)	4 3/4 (111)	—	—	6 7/8 (175)	2 7/8 (73)	3 5/8 (92)	6 3/8 (162)	18 (8)	—	—
1 (25)	5 3/8 (137)	5 1/2 (140)	6 (152)	6 7/8 (175)	3 5/8 (92)	4 3/8 (111)	6 5/8 (168)	18 (8)	27 (129)	30 (14)
1 1/4 (32)	6 1/2 (165)	6 3/4 (171)	7 1/4 (184)	9 1/8 (232)	4 1/8 (105)	4 (102)	7 3/4 (197)	37 (17)	39 (18)	44 (20)
1 1/2 (38)	7 1/4 (184)	6 7/8 (175)	7 3/8 (187)	9 1/8 (232)	4 3/8 (111)	4 1/2 (114)	7 7/8 (200)	42 (19)	50 (23)	56 (25)
2 (51)	7 1/2 (191)	8 1/2 (216)	9 (229)	11 1/8 (283)	5 1/4 (133)	5 (127)	8 5/8 (219)	66 (30)	73 (33)	81 (37)
2 1/2 (64)	—	9 3/8 (238)	10 (254)	11 1/8 (283)	5 3/4 (146)	5 3/8 (137)	9 (229)	—	83 (38)	95 (43)
3 (76)	—	10 (254)	10 3/4 (273)	13 1/2 (343)	6 5/8 (168)	6 3/8 (162)	9 7/8 (251)	—	124 (56)	146 (66)
4 (102)	—	11 7/8 (302)	12 1/2 (318)	13 1/2 (343)	7 5/8 (194)	6 5/8 (168)	12 3/4 (324)	—	206 (94)	234 (106)
5 (127)	—	13 3/8 (346)	14 1/2 (368)	13 1/2 (343)	8 1/2 (216)	7 3/8 (187)	13 1/4 (337)	—	275 (125)	287 (130)
6 (152)	—	15 1/8 (384)	16 (406)	16 3/4 (425)	10 (254)	7 (178)	15 1/2 (394)	—	363 (165)	431 (196)
8 (203)	—	19 (483)	20 (508)	16 3/4 (425)	11 1/2 (292)	9 1/4 (235)	17 5/8 (448)	—	508 (231)	610 (277)

\*Add 100% to D dimension for stem removal clearance.

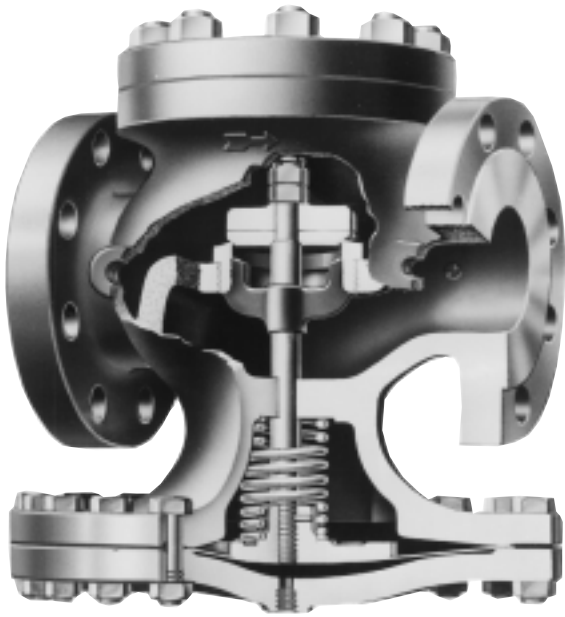

TYPE E8 MAIN VALVE

# TYPE E8 MAIN VALVE

## AIR LOADED

SIZES  $\frac{3}{8}$ " - 12"  
PRESSURES to 250 PSIG at 406°F

- Normally Closed
- Single Seat
- Balanced Metal Diaphragms
- ANSI/FCI 70-2 Class IV Shutoff
- No Minimum Operating Differential Pressure
- Packless Construction
- No Pilot Needed
- Maximum 50 PSI Air Delivery Pressure
- Permits Remote Operation and Control
- Economical Alternative to Control Valve

### APPLICATION DATA

- Pressure Regulating for Steam Distribution
- Regulating for Process Control (Temperature or Pressure)
- Maintain Back Pressure or Differential Pressure
- To use Air Load Pressure to Control Delivery Pressure
- Single Point or Multiple Use Applications
- Slow Start-up or Shutdown
- Use where "Dirty Steam" Conditions Exist

### VALVE RATINGS

Valve Ends ASME/ANSI	Pressure PSIG (bar)	Temperature °F (°C)
-------------------------	------------------------	------------------------

#### CAST IRON

Class 250 NPT	250 (17.2)	@ 450 (232)
B16.1 Class 125 Flanged	125 (8.6)	@ 450 (232)
B16.1 Class 250 Flanged	250 (17.2)	@ 450 (232)

Canadian Registration # OC 0591.9C

### OPTIONS *See page 42*

- Composition Disc
- Balanced Construction
- Insulcap Insulating Jacket
- Parabolic Disc
- Dashpot
- EZ Connections

### TYPICAL CONFIGURATIONS

- PRESSURE REDUCING .....TYPE E8 65A
- PRESSURE REDUCING .....TYPE E8 A PANEL
- PRESSURE REDUCING .....TYPE E8 B PANEL
- PRESSURE REDUCING .....TYPE E8EPC
- TEMPERATURE CONTROL .....TYPE E8T61
- TEMPERATURE CONTROL .....TYPE E8EPC

*Installation Tip:* Add EZ Connections for ease of maintenance  
SEE PAGE 42

SIZING INFO  
PAGE 108

### RATED FLOW COEFFICIENTS (Cv)

SEAT FACTOR	REGULATOR SIZE															
	$\frac{3}{8}$	$\frac{1}{2}$	$\frac{3}{4}$	1	1 $\frac{1}{4}$	1 $\frac{1}{2}$	2	2 $\frac{1}{2}$	3	4	5	6	8	10	12	
Full	1.5	2.8	5.4	8.8	14.1	19.8	31	44	74	109	169	248	444	706	1113	
Full 75 %	—	2.1	4.0	6.6	10.6	14.8	23.3	33	56	82	127	186	333	530	835	
Full 50 %	—	1.4	2.7	4.4	7.0	9.9	15.5	22	37	55	85	124	222	353	557	
Normal	.65	1.5	4.8	7.5	10.4	14.6	17.6	24	43	78	115	151	249	377	631	
Normal 75 %	—	—	—	—	—	—	—	18	33	59	87	114	187	283	474	
Normal 50 %	—	—	—	—	—	—	—	12	22	39	58	76	125	189	316	

# TYPE E8 MAIN VALVE SPECIFICATION

The valve shall be air operated, single seated, metal diaphragm actuated, normally closed design. The valve will function quickly and shut tight on dead end service. Internal parts including seats, discs, stems and diaphragms shall be of stainless steel. There shall be no springs in the steam space and no stuffing box. The valve shall be easy to maintain with all parts accessible without removal from the line.

## MATERIALS OF CONSTRUCTION

Body, Cast Iron .....ASTM A126 Cl. B  
 Body, Cast Bronze .....ASTM B61 UNS C92200  
 Stem .....303 St. Stl. ASTM A582  
 Disc 3/4 - 5" .....420 St. Stl. ASTM A743 CA-40  
 Disc 6 - 12" .....304 St. Stl. ASTM A167/A240  
 Seat 3/4 - 5" .....420 St. Stl. ASTM A743 CA-40  
 Seat 6 - 12" .....316 St. Stl. ASTM A743-79 CF-8M  
 Gasket .....Non-asbestos  
 Diaphragm .....Stainless Steel MIL-S-5059C  
 Spring .....Steel

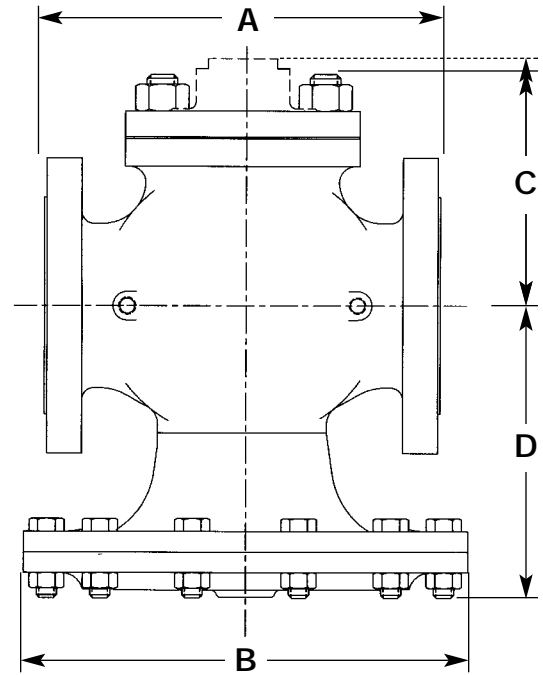

TYPE E MAIN VALVE

TYPE E8  
MAIN VALVE

FITTINGS ON  
PAGE 46

## DIMENSIONS inches (mm) AND WEIGHTS pounds (kg)

SIZE	FACE TO FACE DIMENSIONS					OTHER DIMENSIONS					APPROX. WT.					
	A					B	C		D	E						
	ANSI NPT	ANSI 125,150	ANSI 250	ANSI 300	ANSI 600			ANSI 600			ANSI NPT	ANSI 125	ANSI 150	ANSI 250	ANSI 300	ANSI 600
3/8 (10)	4 3/8 (111)	—	—	—	—	5 7/8 (149)	2 3/4 (70)	—	5 1/4 (133)	7 3/8 (187)	14 (31)	—	—	—	—	—
1/2 (12)	4 3/8 (111)	—	—	—	6 (152)	5 7/8 (149)	2 3/4 (70)	2 3/4 (70)	5 1/4 (133)	7 3/8 (187)	14 (31)	—	—	—	—	20 (44)
3/4 (19)	4 3/8 (111)	—	—	—	6 3/8 (162)	6 1/2 (165)	2 7/8 (73)	3 3/8 (98)	5 1/2 (140)	7 7/8 (200)	18 (40)	—	—	—	—	28 (62)
1 (25)	5 3/8 (137)	5 1/2 (140)	6 (152)	6 1/2 (165)	6 1/2 (165)	7 (178)	3 5/8 (92)	4 1/4 (108)	6 1/4 (159)	8 7/8 (225)	23 (51)	24 (53)	26 (57)	27 (59)	31 (68)	32 (70)
1 1/4 (32)	6 1/2 (165)	6 3/4 (171)	7 1/4 (184)	7 7/8 (200)	7 7/8 (200)	7 7/8 (200)	4 1/8 (105)	4 5/8 (117)	6 1/2 (165)	9 1/8 (232)	33 (73)	36 (79)	37 (81)	40 (88)	41 (90)	45 (99)
1 1/2 (38)	7 1/4 (184)	6 7/8 (175)	7 3/8 (187)	8 (203)	8 (203)	8 3/4 (222)	4 3/8 (111)	5 1/8 (130)	7 1/8 (181)	9 3/4 (248)	43 (95)	45 (99)	47 (103)	51 (112)	55 (121)	58 (128)
2 (51)	7 1/2 (191)	8 1/2 (216)	9 (229)	10 1/4 (260)	10 1/4 (260)	9 7/8 (251)	5 1/4 (133)	5 3/4 (146)	7 5/8 (194)	11 1/4 (286)	62 (136)	67 (147)	73 (161)	72 (158)	78 (172)	83 (183)
2 1/2 (64)	—	9 3/8 (238)	10 (254)	11 1/4 (286)	11 1/4 (286)	10 7/8 (276)	5 3/4 (146)	7 7/8 (200)	8 3/8 (213)	12 1/8 (308)	—	82 (180)	95 (209)	100 (220)	100 (220)	130 (286)
3 (76)	—	10 (254)	10 3/4 (273)	12 1/4 (311)	12 1/4 (311)	11 3/4 (298)	6 5/8 (168)	9 1/8 (232)	9 1/4 (235)	14 5/8 (371)	—	110 (242)	125 (275)	130 (286)	140 (308)	175 (385)
4 (102)	—	11 7/8 (302)	12 1/2 (318)	12 1/2 (318)	14 1/2 (368)	14 3/4 (375)	7 5/8 (194)	10 5/8 (270)	11 7/8 (302)	18 1/4 (464)	—	200 (440)	210 (462)	235 (517)	230 (506)	310 (682)
5 (127)	—	13 5/8 (346)	14 1/2 (368)	14 1/2 (368)	16 1/2 (419)	16 7/8 (429)	8 1/2 (216)	12 1/2 (318)	12 1/2 (318)	20 1/8 (511)	—	280 (616)	295 (649)	315 (693)	310 (682)	490 (1078)
6 (152)	—	15 1/8 (384)	16 (406)	16 (406)	17 3/8 (441)	19 3/4 (502)	10 (254)	13 3/4 (349)	14 1/8 (359)	22 3/8 (568)	—	385 (847)	420 (924)	455 (1001)	470 (1034)	655 (1441)
8 (203)	—	19 (483)	20 (508)	20 (508)	21 5/8 (549)	22 1/2 (572)	11 1/2 (292)	15 5/8 (391)	17 1/4 (438)	27 3/4 (705)	—	657 (1445)	700 (1540)	735 (1617)	710 (1562)	1070 (2354)
10 (254)	—	23 5/8 (600)	25 (635)	25 (635)	—	28 (711)	13 3/4 (349)	—	23 3/8 (594)	36 1/4 (921)	—	1260 (2772)	1240 (2728)	1430 (3146)	1300 (2860)	—
12 (305)	—	26 1/2 (673)	28 (711)	28 (711)	—	33 (838)	15 7/8 (403)	—	25 1/4 (641)	41 1/2 (1054)	—	2070 (4554)	2060 (4532)	2145 (4719)	2140 (4708)	—

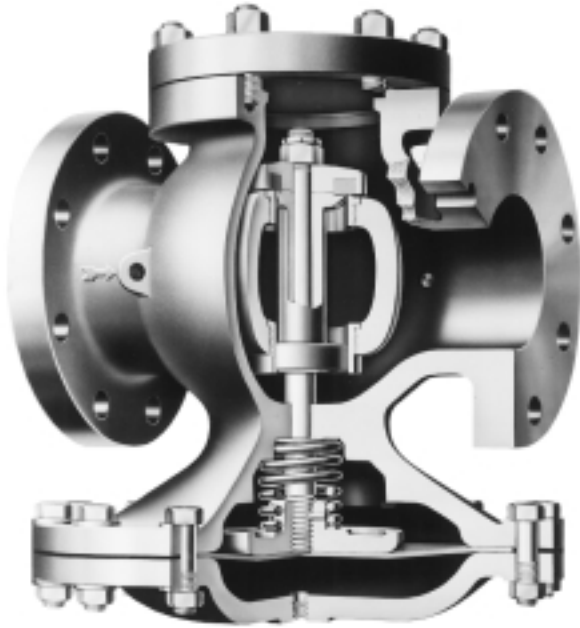

TYPE C34 MAIN VALVE

# TYPE C34 MAIN VALVE

## BALANCED SINGLE SEAT LIQUID SERVICE

SIZES 1" – 6"

PRESSURES to 200 PSIG at 200°F

- Normally Closed
- Single Seat
- Hycar Diaphragm
- Balanced Composition Disc
- Protected Main Spring
- Balanced Piston Design without Dashpot
- Fluid Applications
- Accurate Regulation for Non-violent Load Fluctuations
- ANSI/FCI 70-2 Class VI Shutoff
- Virtually Frictionless for Long Service Life
- Packless Construction
- Wide Variety of Pilots for Many Applications

### OPTIONS *See page 42*

- EZ Connections

### APPLICATION DATA

- Pressure Regulating for Liquid Distribution
- Regulating for Process Control (Temperature or Pressure)
- Maintain Back Pressure or Differential Pressure
- For use with Self-contained, Pneumatic or Electronic Pilots
- Single Point or Multiple Use Applications
- Slow Start-up or Shutdown

### VALVE RATINGS

Valve Ends ASME/ANSI	Pressure PSIG (bar)	Temperature °F (°C)
-------------------------	------------------------	------------------------

#### CAST IRON

B16.4 Class 250 NPT	200 (13.8)	@ 200 (93)
B16.1 Class 125 Flanged	165 (11.4)	@ 200 (93)
B16.1 Class 250 Flanged	200 (13.8)	@ 200 (93)

Canadian Registration # OC 0591.9C

*Installation Tip:* Add EZ Connections for ease of maintenance  
SEE PAGE 42

SIZING INFO  
PAGE 108

### TYPICAL CONFIGURATIONS

- PRESSURE REDUCING .....TYPE C34D
- AIR ADJUSTED .....TYPE C34A
- BACK PRESSURE .....TYPE C34Q
- PUMP GOVERNOR .....TYPE C34P
- LOAD ALLOCATING .....TYPE C34FD
- AIR CONTROLLED .....TYPE C34AP60
- ELECTRONIC SLOW START .....TYPE C34D208D
- SOLENOID CONTROLLED .....TYPE C34MD
- SOLENOID ACTUATED .....TYPE C34M
- DIFFERENTIAL .....TYPE C34N
- COOLING CONTROL .....TYPE C34T

### RATED FLOW COEFFICIENTS (Cv)

REGULATOR SIZE								
1	1¼	1½	2	2½	3	4	5	6
5.5	12.5	17.3	24	36	53	86	139	196

# TYPE C34 MAIN VALVE

## SPECIFICATION

The valve shall be self-operated, external pilot type, single seated, diaphragm actuated, normally closed design. The valve will shut tight on dead end service and shall maintain a discharge pressure which will not vary more than 10% (2 psi minimum) of set point from zero flow to rated flow regardless of inlet pressure variation. Valve shall be suitable for 200°F (93°C) service temperature. Bodies shall be cast iron. Sizes 2-1/2" and larger shall have flanged ends. Trim shall be stainless steel. Valves shall be equipped with a reversible composition disc. Diaphragms and discs shall be hycar. There shall be no springs in the fluid space and no stuffing box.

## MATERIALS OF CONSTRUCTION

Body, Cast Iron .....ASTM A126 Cl. B  
 Stem .....303 St. Stl. ASTM A582  
 Disc .....Hycar Comp  
 Seat 1 - 2" .....303 St. Stl. ASTM A582  
 Seat 2½ - 6" .....304 St. Stl. ASTM A276 Cond A  
 Gasket .....Non-asbestos  
 Diaphragm .....Hycar  
 Spring .....Steel

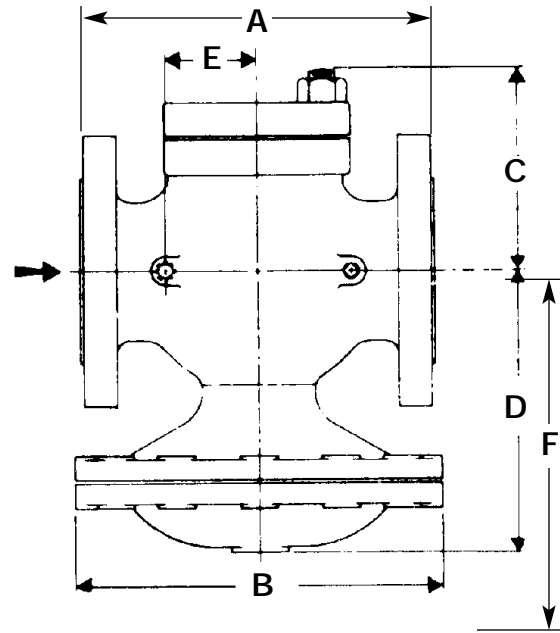

TYPE C34 MAIN VALVE

FITTINGS ON PAGE 46

TYPE C34  
MAIN VALVE

### DIMENSIONS inches (mm) AND WEIGHTS pounds (kg)

SIZE	FACE TO FACE			OTHER DIMENSIONS						APPROX. WT.		
	A			B	C	D	E	F	G	ANSI NPT	ANSI 125	ANSI 250
	ANSI NPT	ANSI 125	ANSI 250									
1 (25)	5 3/8 (137)	—	—	6 7/8 (175)	3 3/8 (86)	7 (178)	1 3/8 (35)	6 (152)	10 3/8 (264)	19 (9)	—	—
1 1/4 (32)	6 1/2 (165)	—	—	6 7/8 (175)	3 7/8 (98)	7 (178)	1 13/16 (46)	6 5/8 (168)	11 1/4 (286)	24 (11)	—	—
1 1/2 (38)	7 1/4 (184)	—	—	6 7/8 (175)	4 1/4 (108)	7 (178)	1 15/16 (49)	6 3/8 (162)	11 7/8 (302)	29 (13)	—	—
2 (51)	7 1/2 (191)	8 1/2 (216)	9 (229)	9 1/8 (232)	4 1/2 (114)	7 (178)	2 1/16 (52)	6 1/2 (165)	12 1/2 (318)	46 (21)	51 (13)	60 (27)
2 1/2 (64)	—	9 3/8 (238)	10 (254)	9 1/8 (232)	5 1/2 (140)	7 3/8 (187)	2 3/8 (60)	6 7/8 (175)	14 1/2 (368)	—	65 (30)	74 (34)
3 (76)	—	10 (254)	10 3/4 (273)	11 1/8 (283)	6 (152)	8 3/4 (222)	2 3/4 (70)	7 1/4 (184)	15 7/8 (403)	—	94 (43)	111 (50)
4 (102)	—	11 7/8 (302)	12 1/2 (318)	13 1/2 (343)	6 5/8 (168)	9 3/8 (238)	3 (76)	7 3/4 (197)	17 3/4 (451)	—	148 (67)	172 (78)
5 (127)	—	13 5/8 (346)	14 1/2 (368)	13 1/2 (343)	7 5/8 (194)	10 7/8 (276)	3 1/2 (89)	8 5/8 (219)	20 1/4 (514)	—	194 (88)	226 (103)
6 (152)	—	15 1/8 (384)	16 (406)	13 1/2 (343)	9 1/8 (232)	13 1/8 (333)	4 1/4 (108)	10 5/8 (270)	25 1/8 (638)	—	280 (127)	325 (148)

NOTES: