

## Applications

- Steam, Liquid, Gas and Oil Service
- Process Equipment
- Power Industry
- Chemical Industry
- Water and Waste
- Pulp and Paper
- Metals and Mining

# T Strainers

Pressures to 3705 PSIG  
Temperatures to 800°F

## FEATURES

- Horizontal or Vertical Installations
- Stainless Steel Perforated Screens
- Thru Bolt Cover is Standard

## MATERIALS

- Stainless Steel
- Carbon Steel
- Other materials upon request

## END CONNECTIONS

- Butt weld End
- RTJ or RF Flanges

## SIZES

- 2" (50mm) up to 24" (600mm) as standard
- Large sizes upon request

## RATINGS

- ASME Class 150
  - ASME Class 300
  - ASME Class 600
  - ASME Class 900
  - ASME Class 1500
- Higher Pressure Classes on Request

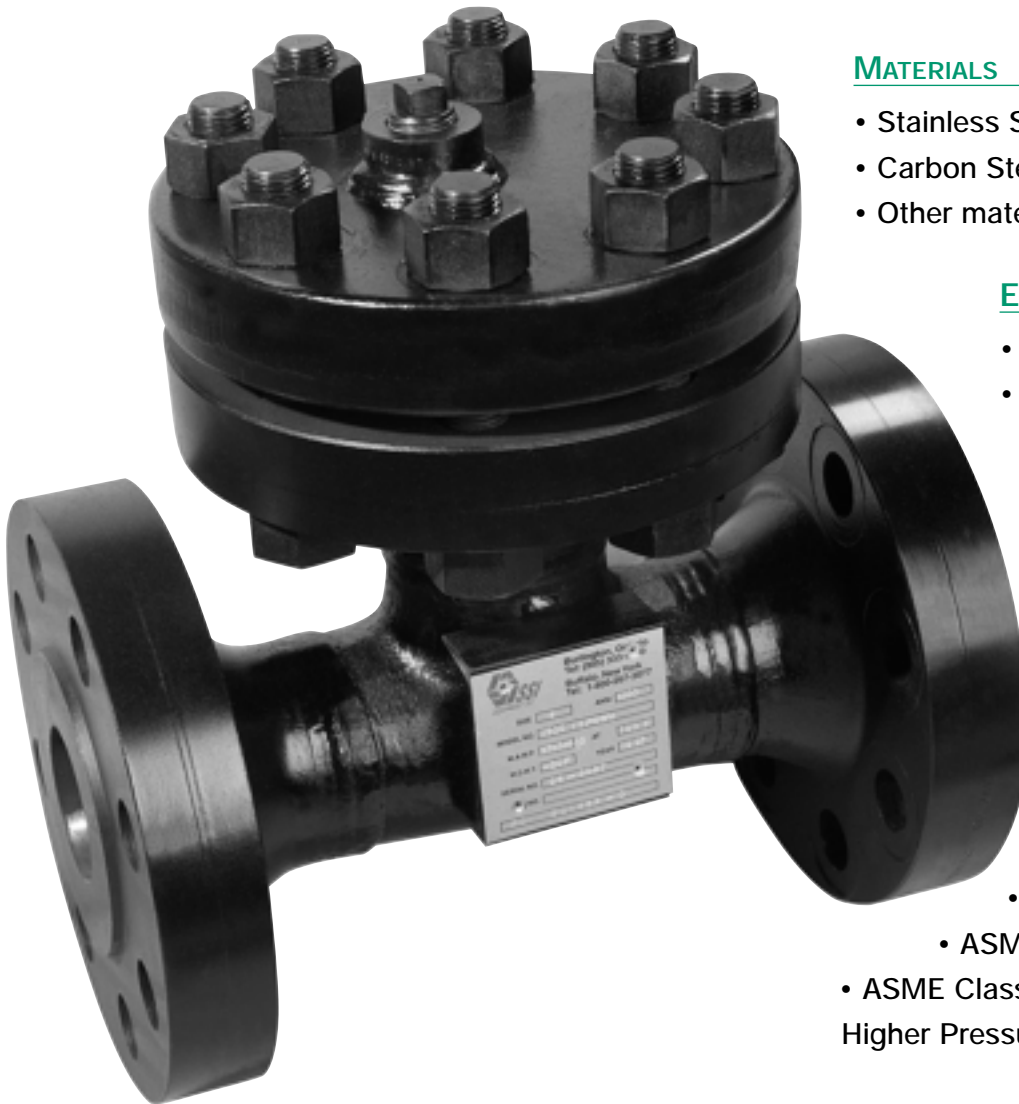

T  
STRAINERS



# FT SERIES FABRICATED T-STRAINERS

PRESSURES TO 3705 PSIG (255 BARG)  
TEMPERATURES TO 800°F (427°C)

- Custom engineered and fabricated T strainers
- RF or RTJ Flanges or Buttweld end connections in accordance with ASME 16.34 and 16.5
- Standard thru bolt cover design.
- Installation in horizontal or vertical pipelines.
- Three flow configurations available.
- Stainless steel perforated screens are standard
- Cover lifting lug standard on sizes 10" and larger

## APPLICATIONS

- Steam, liquid, gas and oil service
- Power Industry
- Pulp & Paper
- Process Equipment
- Chemical Industry
- Metal & Mining
- Water & Waste
- Metal & Mining

## PRESSURE/TEMPERATURE CHART

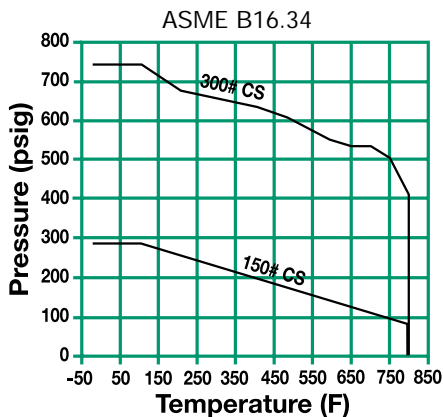

For higher pressure classes & other materials, consult factory.

For Quick Opening Covers see page 92

## MODELS

- FT1 – Inline, straight through flow
- FT2 – 90 degree angle flow – top to side
- FT3 – 90 degree angle flow – side to top
- FTZ – Custom Configuration

## OPTIONS

- Other materials, sizes and/or configurations
- Quick Opening covers – See page 92
- Other screen, mesh or wedgewire – See page 138
- Vent, Drain and/or differential pressure connections
- "U" stamped vessels
- NACE MRO10-75 Certification
- External/Internal coatings
- 600# flanges and higher
- Oxygen cleaning
- Contact Factory for other Options

## APPLICABLE CODES

- Designed/Manufactured to meet ASME B31.1, ASME B31.3, or ASME B31.4 and/or ASME Section VIII, Div. 1.
- Canadian Registration Numbers (CRN) available
- Welders certified to ASME Section IX

## FT Series Ordering Code

| Model | Material | Inlet Size | Class | Connec-<br>tion | Dash | Cover | Perf | Mesh |
|-------|----------|------------|-------|-----------------|------|-------|------|------|
| F T 2 | V P      | 4          | R     | -               | B    | 4     | A    |      |
| 1     | 2        | 3          | 4     | 5               | 6    | 7     | 8    | 9    |
| 10    | 11       |            |       |                 |      |       |      |      |

|  |
|--|
| <p><b>Model</b> - Position 1 - 3</p> <p>FT1 - Inline Flow</p> <p>FT2 - 90 degree angle flow - Top to Side</p> <p>FT3 - 90 degree angle flow - Side to Top</p> <p>FTZ - Custom Configurations</p> |
| <p><b>Material</b> - Position 4</p> <p>C - Carbon Steel</p> <p>L - Low Temp CS</p> <p>V - 304 SS</p> <p>T - 316 SS</p> <p>M - Monel</p> <p>Z - Other</p>   |

|  |
|--|
| <p><b>Inlet Size</b> - Position 5</p> <p>H - 2 U - 16</p> <p>J - 2½ V - 18</p> <p>K - 3 W - 20</p> <p>M - 4 X - 22</p> <p>N - 5 Y - 24</p> <p>P - 6 1 - 28</p> <p>Q - 8 2 - 30</p> <p>R - 10 3 - 36</p> <p>S - 12 4 - 40</p> <p>T - 14 Z - Other</p> |
| <p><b>Class</b> - Position 6</p> <p>1 - 150</p> <p>2 - 250</p> <p>3 - 300</p> <p>4 - 600</p> <p>5 - 900</p> <p>6 - 1500</p> <p>Z - Other</p>   |

|  |
|--|
| <p><b>Connection</b> - Position 7</p> <p>B - Butt Weld<sup>1</sup></p> <p>F - Flat Face Flange</p> <p>J - Ring Joint Flange</p> <p>R - Raised Face Flange</p> <p>Z - Other</p>   |
| <p><b>Dash</b> - Position 8</p>  |
| <p><b>Cover</b> - Position 9</p> <p>B - Bolted</p> <p>C - Bolted w/C-Clamp</p> <p>D - Bolted w/Davit</p> <p>J - Bolted w/Hinge</p> <p>H - T - Bolt Hinged</p> <p>T - Threaded Hinged</p> <p>Y - Yoke Hinged</p> <p>Z - Other</p> |

|  |
|--|
| <p><b>Perf</b> - Position 10</p> <p><b>304 SS Material<sup>2</sup></b></p> <p>B - 3/64"</p> <p>1 - 1/32"</p> <p>2 - 1/16"</p> <p>3 - 3/32"</p> <p>4 - 1/8"</p> <p>5 - 5/32"</p> <p>6 - 3/16"</p> <p>7 - 7/32"</p> <p>8 - 1/4"</p> <p>9 - 3/8"</p> <p>Z - Other</p> |
|--|

|  |
|--|
| <p><b>Mesh<sup>2</sup></b></p> <p>Position 11</p> <p>A - None</p> <p>1 - 10</p> <p>2 - 20</p> <p>3 - 30</p> <p>4 - 40</p> <p>5 - 50</p> <p>6 - 60</p> <p>7 - 80</p> <p>8 - 100</p> <p>9 - 120</p> <p>Z - Other</p> |
|--|

1. For Buttweld connections please specify mating pipe schedule.  
2. For other screen material, contact factory.

For any variations, use the part numbering system above but clearly indicate the additional requirements.

# FT1 SERIES FABRICATED T-STRAINERS

## SPECIFICATION

T Strainer shall be designed and manufactured to meet ASME B31.1, ASME B31.3 or ANSI B31.4 and/or ASME Section VIII Div. 1. The strainer shall be straight flow design with vertical screen supports. The screen shall be size \_\_\_\_\_ perf Stainless Steel. The strainer shall have a bolted cover furnished. The strainer shall have an inlet size of \_\_\_\_\_ and Open Area Ratio of \_\_\_\_\_. The T Strainer shall be SSI FT1 Series.

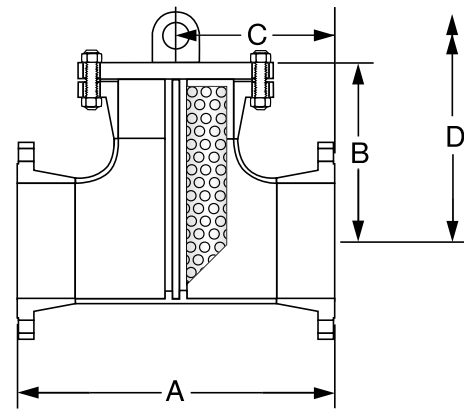

## MATERIALS OF CONSTRUCTION (CARBON STEEL SHOWN\*)

|                             |                     |
|-----------------------------|---------------------|
| Part .....                  | Carbon Steel        |
| Body .....                  | SA234-WPB           |
| Flanges .....               | SA105               |
| Screen <sup>1</sup> .....   | 304 SS              |
| Internal support ribs ..... | Carbon Steel        |
| Coupling / threadolts ..... | SA105               |
| Gasket <sup>1</sup> .....   | 304 SS Spiral Wound |
| Stud .....                  | SA193-B7            |
| Nut .....                   | SA194-2H            |

\* Other material available - consult factory

### 1. Recommended Spare Parts

Materials specification will change when NACE MR01-75 is specified.

Connections: 2-24"  
RF, RTJ or Buttweld<sup>2</sup>

2. For Buttweld connection please specify mating pipe shedule.

## SCREEN OPENINGS

| SIZE     | STANDARD SCREEN | MATERIALS |
|----------|-----------------|-----------|
| 2"- 12"  | 1/8" Perf.      | 304SS     |
| 14"- 24" | 3/16" Perf.     | 304SS     |

## DIMENSIONS inches (mm) AND WEIGHTS pounds (kg)

150# and 300# Class flanges shown (For 600#, 900# and 1500# dimensions and weights - contact factory)

| Size                                  | A   |   | B  |  | C  |  | D  |  | Approx. Weights                          |  |   |   |                |                |                   |                  |                    |                  |
|---------------------------------------|---|---|--|--|--|--|--|--|--|--|---|---|----------------|----------------|-------------------|------------------|--------------------|------------------|
|                                       | Flanged                                   |   | Buttweld                                 |  | Flanged/<br>Buttweld                     |  | Flanged                                  |  | Buttweld                                 |  | Flanged/<br>Buttweld                      |   | Cover          |                | Unit<br>(Flanged) |                  | Unit<br>(Buttweld) |                  |
|                                       | CLASS                                     |   | CLASS                                    |  | CLASS                                    |  | CLASS                                    |  | CLASS                                    |  | CLASS                                     |   | CLASS          |                | CLASS             |                  | CLASS              |                  |
|                                       | 150                                       | 300                                       | 150                                      | 300                                      | 150                                      | 300                                      | 150                                      | 300                                      | 150                                      | 300                                      | 150                                       | 300                                       | 150            | 300            | 150               | 300              | 150                | 300              |
| 2<br>(50)                             | 10 <sup>3</sup> / <sub>16</sub><br>(259)  | 10 <sup>1</sup> / <sub>16</sub><br>(271)  | 5<br>(127)                               | 5<br>(127)                               | 6<br>(152)                               | 6 <sup>1</sup> / <sub>16</sub><br>(161)  | 5 <sup>1</sup> / <sub>16</sub><br>(129)  | 5 <sup>1</sup> / <sub>16</sub><br>(136)  | 2 <sup>1</sup> / <sub>2</sub><br>(63)    | 2 <sup>1</sup> / <sub>2</sub><br>(63)    | 11 <sup>1</sup> / <sub>16</sub><br>(282)  | 11 <sup>1</sup> / <sub>16</sub><br>(294)  | 5<br>(2.3)     | 8<br>(3.6)     | 28<br>(12.7)      | 42<br>(19.1)     | 16<br>(7.3)        | 24<br>(10.9)     |
| 2 <sup>1</sup> / <sub>2</sub><br>(65) | 11 <sup>1</sup> / <sub>16</sub><br>(297)  | 12 <sup>3</sup> / <sub>16</sub><br>(310)  | 6<br>(152)                               | 6<br>(152)                               | 6 <sup>1</sup> / <sub>16</sub><br>(171)  | 7 <sup>1</sup> / <sub>16</sub><br>(180)  | 5 <sup>1</sup> / <sub>16</sub><br>(148)  | 6 <sup>1</sup> / <sub>16</sub><br>(155)  | 3<br>(76)                                | 3<br>(76)                                | 13 <sup>3</sup> / <sub>16</sub><br>(331)  | 13 <sup>3</sup> / <sub>16</sub><br>(344)  | 7<br>(3.2)     | 14<br>(6.4)    | 40<br>(18.1)      | 55<br>(24.9)     | 25<br>(11.3)       | 30<br>(13.6)     |
| 3<br>(80)                             | 12 <sup>3</sup> / <sub>16</sub><br>(316)  | 13 <sup>1</sup> / <sub>16</sub><br>(335)  | 6 <sup>3</sup> / <sub>16</sub><br>(172)  | 6 <sup>3</sup> / <sub>16</sub><br>(172)  | 7 <sup>1</sup> / <sub>16</sub><br>(185)  | 7 <sup>1</sup> / <sub>16</sub><br>(199)  | 6 <sup>1</sup> / <sub>16</sub><br>(158)  | 6 <sup>1</sup> / <sub>16</sub><br>(167)  | 3 <sup>1</sup> / <sub>2</sub><br>(86)    | 3 <sup>1</sup> / <sub>2</sub><br>(86)    | 13 <sup>1</sup> / <sub>16</sub><br>(352)  | 14 <sup>1</sup> / <sub>16</sub><br>(371)  | 9<br>(4.1)     | 16<br>(7.3)    | 52<br>(23.6)      | 72<br>(32.7)     | 32<br>(14.5)       | 42<br>(19.1)     |
| 4<br>(100)                            | 14 <sup>1</sup> / <sub>16</sub><br>(367)  | 15 <sup>3</sup> / <sub>16</sub><br>(386)  | 8 <sup>1</sup> / <sub>16</sub><br>(210)  | 8 <sup>1</sup> / <sub>16</sub><br>(210)  | 8 <sup>1</sup> / <sub>16</sub><br>(210)  | 9<br>(228)                               | 7 <sup>1</sup> / <sub>16</sub><br>(183)  | 7 <sup>1</sup> / <sub>16</sub><br>(193)  | 4 <sup>1</sup> / <sub>16</sub><br>(105)  | 4 <sup>1</sup> / <sub>16</sub><br>(105)  | 16 <sup>3</sup> / <sub>16</sub><br>(415)  | 17 <sup>1</sup> / <sub>16</sub><br>(434)  | 17<br>(7.7)    | 27<br>(12.2)   | 79<br>(35.8)      | 125<br>(56.7)    | 49<br>(22.2)       | 75<br>(34)       |
| 5<br>(125)                            | 16 <sup>1</sup> / <sub>16</sub><br>(430)  | 17 <sup>1</sup> / <sub>16</sub><br>(449)  | 9 <sup>1</sup> / <sub>16</sub><br>(248)  | 9 <sup>1</sup> / <sub>16</sub><br>(248)  | 9 <sup>1</sup> / <sub>16</sub><br>(242)  | 10 <sup>1</sup> / <sub>16</sub><br>(263) | 8 <sup>1</sup> / <sub>16</sub><br>(215)  | 8 <sup>1</sup> / <sub>16</sub><br>(225)  | 4 <sup>1</sup> / <sub>16</sub><br>(124)  | 4 <sup>1</sup> / <sub>16</sub><br>(124)  | 19 <sup>1</sup> / <sub>16</sub><br>(491)  | 20 <sup>1</sup> / <sub>16</sub><br>(510)  | 20<br>(9.1)    | 35<br>(15.9)   | 105<br>(47.6)     | 160<br>(72.6)    | 67<br>(30.4)       | 96<br>(43.5)     |
| 6<br>(150)                            | 18 <sup>1</sup> / <sub>16</sub><br>(468)  | 19 <sup>3</sup> / <sub>16</sub><br>(487)  | 11 <sup>1</sup> / <sub>16</sub><br>(286) | 11 <sup>1</sup> / <sub>16</sub><br>(286) | 10 <sup>3</sup> / <sub>16</sub><br>(263) | 11 <sup>3</sup> / <sub>16</sub><br>(283) | 9 <sup>1</sup> / <sub>16</sub><br>(234)  | 9 <sup>1</sup> / <sub>16</sub><br>(244)  | 5 <sup>1</sup> / <sub>16</sub><br>(143)  | 5 <sup>1</sup> / <sub>16</sub><br>(143)  | 21 <sup>3</sup> / <sub>16</sub><br>(542)  | 22 <sup>1</sup> / <sub>16</sub><br>(561)  | 26<br>(11.8)   | 50<br>(22.7)   | 140<br>(63.5)     | 225<br>(102.1)   | 92<br>(41.7)       | 141<br>(64)      |
| 8<br>(200)                            | 22 <sup>3</sup> / <sub>16</sub><br>(564)  | 22 <sup>1</sup> / <sub>16</sub><br>(583)  | 14<br>(356)                              | 14<br>(356)                              | 12 <sup>3</sup> / <sub>16</sub><br>(314) | 13 <sup>1</sup> / <sub>16</sub><br>(336) | 11 <sup>1</sup> / <sub>16</sub><br>(282) | 11 <sup>1</sup> / <sub>16</sub><br>(291) | 7<br>(178)                               | 7<br>(178)                               | 26 <sup>1</sup> / <sub>16</sub><br>(663)  | 26 <sup>1</sup> / <sub>16</sub><br>(682)  | 45<br>(20.4)   | 81<br>(36.7)   | 230<br>(104.3)    | 350<br>(158.8)   | 152<br>(68.9)      | 216<br>(98)      |
| 10<br>(250)                           | 25 <sup>3</sup> / <sub>16</sub><br>(640)  | 26 <sup>1</sup> / <sub>16</sub><br>(672)  | 17<br>(432)                              | 17<br>(432)                              | 13 <sup>1</sup> / <sub>16</sub><br>(353) | 15 <sup>1</sup> / <sub>16</sub><br>(387) | 12 <sup>3</sup> / <sub>16</sub><br>(320) | 13 <sup>1</sup> / <sub>16</sub><br>(336) | 8 <sup>1</sup> / <sub>16</sub><br>(216)  | 8 <sup>1</sup> / <sub>16</sub><br>(216)  | 30 <sup>3</sup> / <sub>16</sub><br>(764)  | 31 <sup>1</sup> / <sub>16</sub><br>(796)  | 70<br>(31.8)   | 124<br>(56.2)  | 325<br>(147.4)    | 495<br>(224.5)   | 221<br>(100.2)     | 313<br>(142)     |
| 12<br>(300)                           | 29 <sup>3</sup> / <sub>16</sub><br>(741)  | 30 <sup>1</sup> / <sub>16</sub><br>(773)  | 20<br>(508)                              | 20<br>(508)                              | 16<br>(406)                              | 17 <sup>1</sup> / <sub>16</sub><br>(441) | 14 <sup>1</sup> / <sub>16</sub><br>(371) | 15 <sup>1</sup> / <sub>16</sub><br>(387) | 10<br>(254)                              | 10<br>(254)                              | 35 <sup>1</sup> / <sub>16</sub><br>(891)  | 36 <sup>1</sup> / <sub>16</sub><br>(923)  | 110<br>(49.9)  | 185<br>(83.9)  | 500<br>(226.8)    | 765<br>(347)     | 340<br>(154.2)     | 485<br>(220)     |
| 14<br>(350)                           | 32 <sup>3</sup> / <sub>16</sub><br>(818)  | 33 <sup>1</sup> / <sub>16</sub><br>(849)  | 22<br>(559)                              | 22<br>(559)                              | 17 <sup>1</sup> / <sub>16</sub><br>(447) | 19<br>(482)                              | 16 <sup>1</sup> / <sub>16</sub><br>(409) | 16 <sup>1</sup> / <sub>16</sub><br>(425) | 11<br>(279)                              | 11<br>(279)                              | 39 <sup>1</sup> / <sub>16</sub><br>(993)  | 40 <sup>1</sup> / <sub>16</sub><br>(1025) | 140<br>(63.5)  | 250<br>(113.4) | 710<br>(322.1)    | 1025<br>(464.9)  | 490<br>(222.3)     | 665<br>(301.6)   |
| 16<br>(400)                           | 34 <sup>3</sup> / <sub>16</sub><br>(868)  | 35 <sup>1</sup> / <sub>16</sub><br>(906)  | 24<br>(610)                              | 24<br>(610)                              | 18 <sup>1</sup> / <sub>16</sub><br>(474) | 20 <sup>1</sup> / <sub>16</sub><br>(514) | 17 <sup>1</sup> / <sub>16</sub><br>(434) | 17 <sup>1</sup> / <sub>16</sub><br>(453) | 12<br>(305)                              | 12<br>(305)                              | 42 <sup>1</sup> / <sub>16</sub><br>(1069) | 43 <sup>1</sup> / <sub>16</sub><br>(1107) | 180<br>(81.6)  | 295<br>(133.8) | 860<br>(390.1)    | 1320<br>(598.8)  | 580<br>(263.1)     | 820<br>(372)     |
| 18<br>(450)                           | 38 <sup>3</sup> / <sub>16</sub><br>(970)  | 39 <sup>1</sup> / <sub>16</sub><br>(1008) | 27<br>(686)                              | 27<br>(686)                              | 20 <sup>3</sup> / <sub>16</sub><br>(528) | 22 <sup>1</sup> / <sub>16</sub><br>(568) | 19 <sup>1</sup> / <sub>16</sub><br>(485) | 19 <sup>1</sup> / <sub>16</sub><br>(504) | 13 <sup>1</sup> / <sub>16</sub><br>(343) | 13 <sup>1</sup> / <sub>16</sub><br>(343) | 47 <sup>1</sup> / <sub>16</sub><br>(1196) | 48 <sup>1</sup> / <sub>16</sub><br>(1234) | 220<br>(99.8)  | 395<br>(179.2) | 1025<br>(464.9)   | 1700<br>(771.1)  | 725<br>(328.9)     | 1060<br>(480.8)  |
| 20<br>(500)                           | 41 <sup>1</sup> / <sub>16</sub><br>(1055) | 42 <sup>1</sup> / <sub>16</sub><br>(1091) | 30<br>(762)                              | 30<br>(762)                              | 22 <sup>3</sup> / <sub>16</sub><br>(574) | 24 <sup>1</sup> / <sub>16</sub><br>(612) | 20 <sup>3</sup> / <sub>16</sub><br>(528) | 21 <sup>1</sup> / <sub>16</sub><br>(545) | 15<br>(381)                              | 15<br>(381)                              | 51 <sup>1</sup> / <sub>16</sub><br>(1307) | 52 <sup>1</sup> / <sub>16</sub><br>(1342) | 285<br>(129.3) | 505<br>(229.1) | 1350<br>(612.4)   | 2250<br>(1020.6) | 990<br>(449.1)     | 1450<br>(657.7)  |
| 24<br>(600)                           | 46 <sup>3</sup> / <sub>16</sub><br>(1173) | 47 <sup>1</sup> / <sub>16</sub><br>(1205) | 34<br>(864)                              | 34<br>(864)                              | 25 <sup>1</sup> / <sub>16</sub><br>(638) | 26 <sup>1</sup> / <sub>16</sub><br>(676) | 23 <sup>1</sup> / <sub>16</sub><br>(587) | 23 <sup>1</sup> / <sub>16</sub><br>(602) | 17<br>(432)                              | 17<br>(432)                              | 58 <sup>1</sup> / <sub>16</sub><br>(1476) | 59 <sup>1</sup> / <sub>16</sub><br>(1507) | 430<br>(195)   | 790<br>(358.3) | 2100<br>(952.6)   | 2340<br>(1061.4) | 1580<br>(716.7)    | 2240<br>(1016.1) |

Note: Cover lifting lugs standard on sizes 10 and larger. Lifting lug dimensions are not included above. Dimensions shown are subject to change. Contact factory for certified prints when required.

T  
STRAINERS



# FT2 SERIES FABRICATED T-STRAINERS

## SPECIFICATION

T Strainer shall be designed and manufactured to meet ASME B31.1, ASME B31.3 or ANSI B31.4 and/or ASME Section VIII Div. 1. The strainer shall be 90 degree angle flow design with horizontal screen supports. The flow shall be top to side. The screen shall be size \_\_\_\_\_ perf Stainless Steel. The strainer shall have a bolted cover furnished. The strainer shall be have an inlet size of \_\_\_\_\_ and Open Area Ratio of \_\_\_\_\_. The T Strainer shall be SSI FT2 Series.

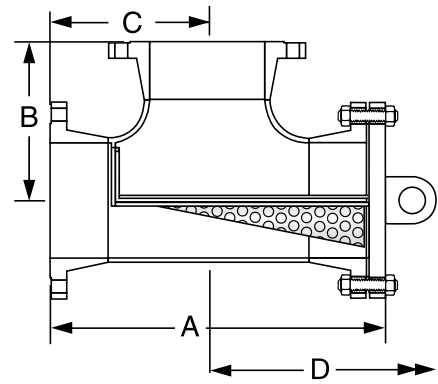

## MATERIALS OF CONSTRUCTION (CARBON STEEL SHOWN\*)

|                             |                     |
|-----------------------------|---------------------|
| Part .....                  | Carbon Steel        |
| Body .....                  | SA234-WPB           |
| Flanges .....               | SA105               |
| Screen <sup>1</sup> .....   | 304 SS              |
| Internal support ribs ..... | Carbon Steel        |
| Coupling / threadolts ..... | SA105               |
| Gasket <sup>1</sup> .....   | 304 SS Spiral Wound |
| Stud .....                  | SA193-B7            |
| Nut .....                   | SA194-2H            |

\* Other material available - consult factory

1. Recommended Spare Parts

Materials specification will change when NACE MR01-75 is specified.

Connections: 2-24"  
RF, RTJ or Buttweld<sup>2</sup>

2. For Buttweld connection please specify mating pipe schedule.

## SCREEN OPENINGS

| SIZE      | STANDARD SCREEN | MATERIALS |
|-----------|-----------------|-----------|
| 2" - 12"  | 1/8" Perf.      | 304SS     |
| 14" - 24" | 3/16" Perf.     | 304SS     |

## DIMENSIONS inches (mm) AND WEIGHTS pounds (kg)

150# and 300# Class flanges shown (For 600#, 900# and 1500# dimensions and weights, contact factory)

| Size                                  | A  |  |  |  | B                                       |   |   |   | C                                       |   |   |   | D  |  | Approx. Weights |                |                   |                  |                    |                  |
|---------------------------------------|--|--|--|--|---|---|---|---|---|---|---|---|--|--|-----------------|----------------|-------------------|------------------|--------------------|------------------|
|                                       | Flanged                                  |  | Buttweld                                 |  | Flanged                                 |   | Buttweld                                |   | Flanged                                 |   | Buttweld                                |   | Flanged/<br>Buttweld                     |  | Cover           |                | Unit<br>(Flanged) |                  | Unit<br>(Buttweld) |                  |
|                                       | CLASS                                    |  | CLASS                                    |  | CLASS                                   |   | CLASS                                   |   | CLASS                                   |   | CLASS                                   |   | CLASS                                    |  | CLASS           |                | CLASS             |                  | CLASS              |                  |
|                                       | 150                                      | 300                                      | 150                                      | 300                                      | 150                                     | 300                                     | 150                                     | 300                                     | 150                                     | 300                                     | 150                                     | 300                                     | 150                                      | 300                                      | 150             | 300            | 150               | 300              | 150                | 300              |
| 2<br>(50)                             | 10 <sup>1</sup> / <sub>8</sub><br>(278)  | 11 <sup>1</sup> / <sub>8</sub><br>(294)  | 8 <sup>1</sup> / <sub>4</sub><br>(209)   | 8 <sup>1</sup> / <sub>8</sub><br>(219)   | 5 <sup>1</sup> / <sub>8</sub><br>(129)  | 5 <sup>3</sup> / <sub>8</sub><br>(136)  | 2 <sup>1</sup> / <sub>2</sub><br>(63)   | 2 <sup>1</sup> / <sub>2</sub><br>(63)   | 5 <sup>1</sup> / <sub>8</sub><br>(129)  | 5 <sup>3</sup> / <sub>8</sub><br>(136)  | 2 <sup>1</sup> / <sub>2</sub><br>(63)   | 2 <sup>1</sup> / <sub>2</sub><br>(63)   | 12 <sup>1</sup> / <sub>8</sub><br>(320)  | 13 <sup>1</sup> / <sub>8</sub><br>(333)  | 5<br>(2.3)      | 8<br>(3.6)     | 28<br>(12.7)      | 42<br>(19.1)     | 16<br>(7.3)        | 24<br>(10.9)     |
| 2 <sup>1</sup> / <sub>2</sub><br>(65) | 12 <sup>3</sup> / <sub>8</sub><br>(314)  | 13<br>(330)                              | 9 <sup>1</sup> / <sub>8</sub><br>(244)   | 10<br>(254)                              | 5 <sup>1</sup> / <sub>8</sub><br>(148)  | 6 <sup>1</sup> / <sub>8</sub><br>(155)  | 3<br>(76)                               | 3<br>(76)                               | 5 <sup>1</sup> / <sub>8</sub><br>(148)  | 6 <sup>1</sup> / <sub>8</sub><br>(155)  | 3<br>(76)                               | 3<br>(76)                               | 14 <sup>1</sup> / <sub>8</sub><br>(377)  | 15 <sup>1</sup> / <sub>8</sub><br>(396)  | 7<br>(3.2)      | 14<br>(6.4)    | 40<br>(18.1)      | 55<br>(24.9)     | 25<br>(11.3)       | 30<br>(13.6)     |
| 3<br>(80)                             | 13 <sup>3</sup> / <sub>8</sub><br>(340)  | 14 <sup>1</sup> / <sub>8</sub><br>(364)  | 10 <sup>1</sup> / <sub>8</sub><br>(265)  | 11<br>(280)                              | 6 <sup>1</sup> / <sub>4</sub><br>(158)  | 6 <sup>3</sup> / <sub>8</sub><br>(167)  | 3 <sup>3</sup> / <sub>8</sub><br>(86)   | 3 <sup>3</sup> / <sub>8</sub><br>(86)   | 6 <sup>1</sup> / <sub>4</sub><br>(158)  | 6 <sup>3</sup> / <sub>8</sub><br>(167)  | 3 <sup>3</sup> / <sub>8</sub><br>(86)   | 3 <sup>3</sup> / <sub>8</sub><br>(86)   | 15 <sup>3</sup> / <sub>8</sub><br>(390)  | 16 <sup>1</sup> / <sub>8</sub><br>(409)  | 9<br>(4.1)      | 16<br>(7.3)    | 52<br>(23.6)      | 72<br>(32.7)     | 32<br>(14.5)       | 42<br>(19.1)     |
| 4<br>(100)                            | 15 <sup>3</sup> / <sub>8</sub><br>(390)  | 16 <sup>1</sup> / <sub>8</sub><br>(418)  | 12 <sup>3</sup> / <sub>8</sub><br>(310)  | 12 <sup>1</sup> / <sub>8</sub><br>(327)  | 7 <sup>1</sup> / <sub>4</sub><br>(183)  | 7 <sup>1</sup> / <sub>8</sub><br>(193)  | 4 <sup>1</sup> / <sub>8</sub><br>(105)  | 4 <sup>1</sup> / <sub>8</sub><br>(105)  | 7 <sup>1</sup> / <sub>4</sub><br>(183)  | 7 <sup>1</sup> / <sub>8</sub><br>(193)  | 4 <sup>1</sup> / <sub>8</sub><br>(105)  | 4 <sup>1</sup> / <sub>8</sub><br>(105)  | 18 <sup>1</sup> / <sub>2</sub><br>(469)  | 19 <sup>1</sup> / <sub>4</sub><br>(488)  | 17<br>(7.7)     | 27<br>(12.2)   | 79<br>(35.8)      | 125<br>(56.7)    | 49<br>(22.2)       | 75<br>(34)       |
| 5<br>(125)                            | 17 <sup>1</sup> / <sub>8</sub><br>(454)  | 19 <sup>1</sup> / <sub>8</sub><br>(484)  | 14 <sup>3</sup> / <sub>8</sub><br>(361)  | 15<br>(381)                              | 8 <sup>1</sup> / <sub>2</sub><br>(215)  | 8 <sup>7</sup> / <sub>8</sub><br>(225)  | 4 <sup>1</sup> / <sub>8</sub><br>(124)  | 4 <sup>1</sup> / <sub>8</sub><br>(124)  | 8 <sup>1</sup> / <sub>2</sub><br>(215)  | 8 <sup>1</sup> / <sub>8</sub><br>(225)  | 4 <sup>1</sup> / <sub>8</sub><br>(124)  | 4 <sup>1</sup> / <sub>8</sub><br>(124)  | 21 <sup>3</sup> / <sub>4</sub><br>(552)  | 22 <sup>1</sup> / <sub>2</sub><br>(571)  | 20<br>(9.1)     | 35<br>(15.9)   | 105<br>(47.6)     | 160<br>(72.6)    | 67<br>(30.4)       | 96<br>(43.5)     |
| 6<br>(150)                            | 19 <sup>1</sup> / <sub>8</sub><br>(494)  | 20 <sup>1</sup> / <sub>8</sub><br>(524)  | 15 <sup>3</sup> / <sub>4</sub><br>(400)  | 16 <sup>1</sup> / <sub>8</sub><br>(421)  | 9 <sup>1</sup> / <sub>4</sub><br>(234)  | 9 <sup>1</sup> / <sub>8</sub><br>(244)  | 5 <sup>1</sup> / <sub>8</sub><br>(143)  | 5 <sup>1</sup> / <sub>8</sub><br>(143)  | 9 <sup>1</sup> / <sub>4</sub><br>(234)  | 9 <sup>1</sup> / <sub>8</sub><br>(244)  | 5 <sup>1</sup> / <sub>8</sub><br>(143)  | 5 <sup>1</sup> / <sub>8</sub><br>(143)  | 23 <sup>3</sup> / <sub>4</sub><br>(604)  | 24 <sup>3</sup> / <sub>4</sub><br>(628)  | 26<br>(11.8)    | 50<br>(22.7)   | 140<br>(63.5)     | 225<br>(102.1)   | 92<br>(41.7)       | 141<br>(64)      |
| 8<br>(200)                            | 23 <sup>1</sup> / <sub>8</sub><br>(592)  | 24 <sup>1</sup> / <sub>8</sub><br>(624)  | 19 <sup>1</sup> / <sub>8</sub><br>(486)  | 20<br>(508)                              | 11<br>(282)                             | 11 <sup>1</sup> / <sub>2</sub><br>(291) | 7<br>(178)                              | 7<br>(178)                              | 11<br>(282)                             | 11 <sup>1</sup> / <sub>2</sub><br>(291) | 7<br>(178)                              | 7<br>(178)                              | 29 <sup>1</sup> / <sub>8</sub><br>(739)  | 29 <sup>1</sup> / <sub>8</sub><br>(758)  | 45<br>(20.4)    | 81<br>(36.7)   | 230<br>(104.3)    | 350<br>(158.8)   | 152<br>(68.9)      | 216<br>(98)      |
| 10<br>(250)                           | 26 <sup>3</sup> / <sub>8</sub><br>(670)  | 28 <sup>1</sup> / <sub>8</sub><br>(719)  | 22 <sup>3</sup> / <sub>8</sub><br>(564)  | 23 <sup>1</sup> / <sub>2</sub><br>(597)  | 12 <sup>5</sup> / <sub>8</sub><br>(320) | 13 <sup>1</sup> / <sub>4</sub><br>(336) | 8 <sup>1</sup> / <sub>2</sub><br>(216)  | 8 <sup>1</sup> / <sub>2</sub><br>(216)  | 12 <sup>5</sup> / <sub>8</sub><br>(320) | 13 <sup>1</sup> / <sub>4</sub><br>(336) | 8 <sup>1</sup> / <sub>2</sub><br>(216)  | 8 <sup>1</sup> / <sub>2</sub><br>(216)  | 33 <sup>5</sup> / <sub>8</sub><br>(853)  | 34 <sup>1</sup> / <sub>8</sub><br>(885)  | 70<br>(31.8)    | 124<br>(56.2)  | 325<br>(147.4)    | 495<br>(224.5)   | 221<br>(100.2)     | 313<br>(142)     |
| 12<br>(300)                           | 30 <sup>1</sup> / <sub>8</sub><br>(773)  | 32 <sup>1</sup> / <sub>8</sub><br>(824)  | 25 <sup>3</sup> / <sub>4</sub><br>(654)  | 27 <sup>1</sup> / <sub>8</sub><br>(689)  | 14 2/4<br>(371)                         | 15 <sup>1</sup> / <sub>4</sub><br>(387) | 10<br>(254)                             | 10<br>(254)                             | 14 2/4<br>(371)                         | 15 <sup>1</sup> / <sub>4</sub><br>(387) | 10<br>(254)                             | 10<br>(254)                             | 39 <sup>1</sup> / <sub>8</sub><br>(993)  | 40 <sup>3</sup> / <sub>8</sub><br>(1025) | 110<br>(49.9)   | 185<br>(83.9)  | 500<br>(226.8)    | 765<br>(347)     | 340<br>(154.2)     | 485<br>(220)     |
| 14<br>(350)                           | 33 <sup>1</sup> / <sub>8</sub><br>(853)  | 35 <sup>1</sup> / <sub>8</sub><br>(903)  | 28 <sup>3</sup> / <sub>8</sub><br>(720)  | 29 <sup>3</sup> / <sub>4</sub><br>(755)  | 16<br>(409)                             | 16 <sup>3</sup> / <sub>4</sub><br>(425) | 11<br>(279)                             | 11<br>(279)                             | 16<br>(409)                             | 16 <sup>3</sup> / <sub>4</sub><br>(425) | 11<br>(279)                             | 11<br>(279)                             | 43 <sup>1</sup> / <sub>8</sub><br>(1095) | 44 <sup>3</sup> / <sub>8</sub><br>(1126) | 140<br>(63.5)   | 250<br>(113.4) | 710<br>(322.1)    | 1025<br>(464.9)  | 490<br>(222.3)     | 665<br>(301.6)   |
| 16<br>(400)                           | 35 <sup>5</sup> / <sub>8</sub><br>(905)  | 37 <sup>1</sup> / <sub>8</sub><br>(964)  | 30 <sup>1</sup> / <sub>8</sub><br>(773)  | 32<br>(813)                              | 17 <sup>1</sup> / <sub>8</sub><br>(434) | 17 <sup>7</sup> / <sub>8</sub><br>(453) | 12<br>(305)                             | 12<br>(305)                             | 17 <sup>1</sup> / <sub>8</sub><br>(434) | 17 <sup>1</sup> / <sub>8</sub><br>(453) | 12<br>(305)                             | 12<br>(305)                             | 46 <sup>1</sup> / <sub>8</sub><br>(1171) | 47 <sup>5</sup> / <sub>8</sub><br>(1209) | 180<br>(81.6)   | 295<br>(133.8) | 860<br>(390.1)    | 1320<br>(598.8)  | 580<br>(263.1)     | 820<br>(372)     |
| 18<br>(450)                           | 39 <sup>3</sup> / <sub>4</sub><br>(1010) | 42 <sup>1</sup> / <sub>8</sub><br>(1069) | 34<br>(865)                              | 35 <sup>5</sup> / <sub>8</sub><br>(905)  | 19 <sup>1</sup> / <sub>8</sub><br>(485) | 19 <sup>7</sup> / <sub>8</sub><br>(504) | 13 <sup>1</sup> / <sub>2</sub><br>(343) | 13 <sup>1</sup> / <sub>2</sub><br>(343) | 19 <sup>1</sup> / <sub>8</sub><br>(485) | 19 <sup>1</sup> / <sub>8</sub><br>(504) | 13 <sup>1</sup> / <sub>2</sub><br>(343) | 13 <sup>1</sup> / <sub>2</sub><br>(343) | 51 <sup>5</sup> / <sub>8</sub><br>(1310) | 53 <sup>1</sup> / <sub>8</sub><br>(1349) | 220<br>(99.8)   | 395<br>(179.2) | 1025<br>(464.9)   | 1700<br>(771.1)  | 725<br>(328.9)     | 1060<br>(480.8)  |
| 20<br>(500)                           | 43 <sup>1</sup> / <sub>4</sub><br>(1098) | 45 <sup>1</sup> / <sub>8</sub><br>(1154) | 37 <sup>3</sup> / <sub>8</sub><br>(949)  | 38 <sup>7</sup> / <sub>8</sub><br>(987)  | 20 <sup>3</sup> / <sub>4</sub><br>(528) | 21 <sup>1</sup> / <sub>2</sub><br>(545) | 15<br>(381)                             | 15<br>(381)                             | 20 <sup>3</sup> / <sub>4</sub><br>(528) | 21 <sup>1</sup> / <sub>2</sub><br>(545) | 15<br>(381)                             | 15<br>(381)                             | 59 <sup>1</sup> / <sub>8</sub><br>(1519) | 62 <sup>1</sup> / <sub>8</sub><br>(1596) | 285<br>(129.3)  | 505<br>(229.1) | 1350<br>(612.4)   | 2250<br>(1020.6) | 990<br>(449.1)     | 1450<br>(657.7)  |
| 24<br>(600)                           | 48 <sup>1</sup> / <sub>8</sub><br>(1221) | 50 <sup>1</sup> / <sub>8</sub><br>(1275) | 41 <sup>7</sup> / <sub>8</sub><br>(1064) | 43 <sup>3</sup> / <sub>8</sub><br>(1102) | 23 <sup>1</sup> / <sub>8</sub><br>(587) | 23 <sup>3</sup> / <sub>4</sub><br>(602) | 17<br>(432)                             | 17<br>(432)                             | 23 <sup>1</sup> / <sub>8</sub><br>(587) | 23 <sup>3</sup> / <sub>4</sub><br>(602) | 17<br>(432)                             | 17<br>(432)                             | 63 <sup>1</sup> / <sub>8</sub><br>(1603) | 64 <sup>3</sup> / <sub>8</sub><br>(1634) | 430<br>(195)    | 790<br>(358.3) | 2100<br>(952.6)   | 2340<br>(1061.4) | 1580<br>(716.7)    | 2240<br>(1016.1) |

Note: Cover lifting lugs standard on sizes 10 and larger. Lifting lug dimensions are not included above. Dimensions shown are subject to change. Contact factory for certified prints when required.



# FT3 SERIES FABRICATED T-STRAINERS

## SPECIFICATION

T Strainer shall be designed and manufactured to meet ASME B31.1, ASME B31.3 or ANSI B31.4 and/or ASME Section VIII Div. 1. The strainer shall be 90 degree angle flow design. The flow shall be side to top. The screen shall be size \_\_\_\_\_ perf Stainless Steel. The strainer shall have a bolted cover furnished. The strainer shall have an inlet size of \_\_\_\_\_ and Open Area Ratio of \_\_\_\_\_. The T Strainer shall be SSI FT3 Series.

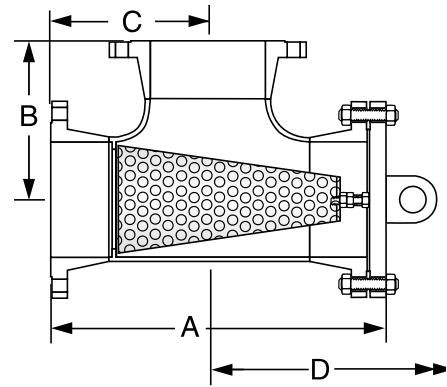

## MATERIALS OF CONSTRUCTION (CARBON STEEL SHOWN\*)

|                             |                     |
|-----------------------------|---------------------|
| Part .....                  | Carbon Steel        |
| Body .....                  | SA234-WPB           |
| Flanges .....               | SA105               |
| Screen <sup>1</sup> .....   | 304 SS              |
| Internal support ribs ..... | Carbon Steel        |
| Coupling / threadolts ..... | SA105               |
| Gasket <sup>1</sup> .....   | 304 SS Spiral Wound |
| Stud .....                  | SA193-B7            |
| Nut .....                   | SA194-2H            |

\* Other material available - consult factory

1. Recommended Spare Parts

Materials specification will change when NACE MR01-75 is specified.

Connections: 2-24"  
RF, RTJ or Buttweld<sup>2</sup>

2. For Buttweld connection please specify mating pipe schedule.

## SCREEN OPENINGS

| SIZE      | STANDARD SCREEN | MATERIALS |
|-----------|-----------------|-----------|
| 2" - 12"  | 1/8" Perf.      | 304SS     |
| 14" - 24" | 3/16" Perf.     | 304SS     |

## DIMENSIONS inches (mm) AND WEIGHTS pounds (kg)

150# and 300# Class flanges shown (For 600#, 900# and 1500# dimensions and weights, contact factory)

| Size          | A  |  | B                                      |              | C                                      |  | D                                     |                                       | Approx. Weights                        |  |                                       |                                       |  |   |                 |                |                 |                  |                 |                  |
|---------------|--|--|--|--------------|--|--|---------------------------------------|---------------------------------------|--|--|---------------------------------------|---------------------------------------|--|---|-----------------|----------------|-----------------|------------------|-----------------|------------------|
|               | Flanged                                  |  | Buttweld                               |              | Flanged                                |  | Buttweld                              |                                       | Flanged/Buttweld                       |  | Cover                                 |                                       | Unit (Flanged)                           |   | Unit (Buttweld) |                |                 |                  |                 |                  |
|               | CLASS                                    |  | CLASS                                  |              | CLASS                                  |  | CLASS                                 |                                       | CLASS                                  |  | CLASS                                 |                                       | CLASS                                    |   | CLASS           |                |                 |                  |                 |                  |
|               | 150                                      | 300                                      | 150                                    | 300          | 150                                    | 300                                    | 150                                   | 300                                   | 150                                    | 300                                    | 150                                   | 300                                   | 150                                      | 300                                     | 150             | 300            |                 |                  |                 |                  |
| 2<br>(50)     | 10 <sup>1</sup> / <sub>16</sub><br>(278) | 11 <sup>1</sup> / <sub>16</sub><br>(294) | 8 <sup>1</sup> / <sub>4</sub><br>(209) | 8<br>(219)   | 5 <sup>1</sup> / <sub>8</sub><br>(129) | 5 <sup>3</sup> / <sub>8</sub><br>(136) | 2 <sup>1</sup> / <sub>2</sub><br>(63) | 2 <sup>1</sup> / <sub>2</sub><br>(63) | 5 <sup>1</sup> / <sub>8</sub><br>(129) | 5 <sup>3</sup> / <sub>8</sub><br>(136) | 2 <sup>1</sup> / <sub>2</sub><br>(63) | 2 <sup>1</sup> / <sub>2</sub><br>(63) | 12 <sup>5</sup> / <sub>16</sub><br>(320) | 13 <sup>1</sup> / <sub>8</sub><br>(333) | 5<br>(2.3)      | 8<br>(3.6)     | 28<br>(12.7)    | 42<br>(19.1)     | 16<br>(7.3)     | 24<br>(10.9)     |
| 2 1/2<br>(65) | 12 <sup>3</sup> / <sub>8</sub><br>(314)  | 13<br>(330)                              | 9<br>(244)                             | 10<br>(254)  | 5<br>(148)                             | 6<br>(155)                             | 3<br>(76)                             | 3<br>(76)                             | 5<br>(148)                             | 6<br>(155)                             | 3<br>(76)                             | 3<br>(76)                             | 14<br>(377)                              | 15<br>(396)                             | 7<br>(3.2)      | 14<br>(6.4)    | 40<br>(18.1)    | 55<br>(24.9)     | 25<br>(11.3)    | 30<br>(13.6)     |
| 3<br>(80)     | 13 <sup>3</sup> / <sub>8</sub><br>(340)  | 14<br>(364)                              | 10<br>(265)                            | 11<br>(280)  | 6<br>(158)                             | 6<br>(167)                             | 3<br>(86)                             | 3<br>(86)                             | 6<br>(158)                             | 6<br>(167)                             | 3<br>(86)                             | 3<br>(86)                             | 15<br>(390)                              | 15<br>(390)                             | 9<br>(4.1)      | 16<br>(7.3)    | 52<br>(23.6)    | 72<br>(32.7)     | 32<br>(14.5)    | 42<br>(19.1)     |
| 4<br>(100)    | 15<br>(390)                              | 16<br>(418)                              | 12<br>(310)                            | 12<br>(327)  | 7<br>(183)                             | 7<br>(193)                             | 4<br>(105)                            | 4<br>(105)                            | 7<br>(183)                             | 7<br>(193)                             | 4<br>(105)                            | 4<br>(105)                            | 18<br>(469)                              | 19<br>(488)                             | 17<br>(7.7)     | 27<br>(12.2)   | 79<br>(35.8)    | 125<br>(56.7)    | 49<br>(22.2)    | 75<br>(34)       |
| 5<br>(125)    | 17<br>(454)                              | 19<br>(484)                              | 14<br>(361)                            | 15<br>(381)  | 8<br>(215)                             | 8<br>(225)                             | 4<br>(124)                            | 4<br>(124)                            | 8<br>(215)                             | 8<br>(225)                             | 4<br>(124)                            | 4<br>(124)                            | 21<br>(552)                              | 22<br>(571)                             | 20<br>(9.1)     | 35<br>(15.9)   | 105<br>(47.6)   | 160<br>(72.6)    | 67<br>(30.4)    | 96<br>(43.5)     |
| 6<br>(150)    | 19<br>(494)                              | 20<br>(524)                              | 15<br>(400)                            | 16<br>(421)  | 9<br>(234)                             | 9<br>(244)                             | 5<br>(143)                            | 5<br>(143)                            | 9<br>(234)                             | 9<br>(244)                             | 5<br>(143)                            | 5<br>(143)                            | 23<br>(604)                              | 24<br>(628)                             | 26<br>(11.8)    | 50<br>(22.7)   | 140<br>(63.5)   | 225<br>(102.1)   | 92<br>(41.7)    | 141<br>(64)      |
| 8<br>(200)    | 23<br>(592)                              | 24<br>(624)                              | 19<br>(486)                            | 20<br>(508)  | 11<br>(282)                            | 11<br>(291)                            | 7<br>(178)                            | 7<br>(178)                            | 11<br>(282)                            | 11<br>(291)                            | 7<br>(178)                            | 7<br>(178)                            | 29<br>(739)                              | 29<br>(758)                             | 45<br>(20.4)    | 81<br>(36.7)   | 230<br>(104.3)  | 350<br>(158.8)   | 152<br>(68.9)   | 216<br>(98)      |
| 10<br>(250)   | 26<br>(670)                              | 28<br>(719)                              | 22<br>(564)                            | 23<br>(597)  | 12<br>(320)                            | 13<br>(336)                            | 8<br>(216)                            | 8<br>(216)                            | 12<br>(320)                            | 13<br>(336)                            | 8<br>(216)                            | 8<br>(216)                            | 33<br>(853)                              | 34<br>(885)                             | 70<br>(31.8)    | 124<br>(56.2)  | 325<br>(147.4)  | 495<br>(224.5)   | 221<br>(100.2)  | 313<br>(142)     |
| 12<br>(300)   | 30<br>(773)                              | 32<br>(824)                              | 25<br>(654)                            | 27<br>(689)  | 14<br>(371)                            | 15<br>(387)                            | 10<br>(254)                           | 10<br>(254)                           | 14<br>(371)                            | 15<br>(387)                            | 10<br>(254)                           | 10<br>(254)                           | 39<br>(993)                              | 40<br>(1025)                            | 110<br>(49.9)   | 185<br>(83.9)  | 500<br>(226.8)  | 765<br>(347)     | 340<br>(154.2)  | 485<br>(220)     |
| 14<br>(350)   | 33<br>(853)                              | 35<br>(903)                              | 28<br>(720)                            | 29<br>(755)  | 16<br>(409)                            | 16<br>(425)                            | 11<br>(279)                           | 11<br>(279)                           | 16<br>(409)                            | 16<br>(425)                            | 11<br>(279)                           | 11<br>(279)                           | 43<br>(1095)                             | 44<br>(1126)                            | 140<br>(63.5)   | 250<br>(113.4) | 710<br>(322.1)  | 1025<br>(464.9)  | 490<br>(222.3)  | 665<br>(301.6)   |
| 16<br>(400)   | 35<br>(905)                              | 37<br>(964)                              | 30<br>(773)                            | 32<br>(813)  | 17<br>(434)                            | 17<br>(453)                            | 12<br>(305)                           | 12<br>(305)                           | 17<br>(434)                            | 17<br>(453)                            | 12<br>(305)                           | 12<br>(305)                           | 46<br>(1171)                             | 47<br>(1209)                            | 180<br>(81.6)   | 295<br>(133.8) | 860<br>(390.1)  | 1320<br>(598.8)  | 580<br>(263.1)  | 820<br>(372)     |
| 18<br>(450)   | 39<br>(1010)                             | 42<br>(1069)                             | 34<br>(865)                            | 35<br>(905)  | 19<br>(485)                            | 19<br>(504)                            | 13<br>(343)                           | 13<br>(343)                           | 19<br>(485)                            | 19<br>(504)                            | 13<br>(343)                           | 13<br>(343)                           | 51<br>(1310)                             | 53<br>(1349)                            | 220<br>(99.8)   | 395<br>(179.2) | 1025<br>(464.9) | 1700<br>(771.1)  | 725<br>(328.9)  | 1060<br>(480.8)  |
| 20<br>(500)   | 43<br>(1098)                             | 45<br>(1154)                             | 37<br>(949)                            | 38<br>(987)  | 20<br>(528)                            | 21<br>(545)                            | 15<br>(381)                           | 15<br>(381)                           | 20<br>(528)                            | 21<br>(545)                            | 15<br>(381)                           | 15<br>(381)                           | 59<br>(1519)                             | 62<br>(1596)                            | 285<br>(129.3)  | 505<br>(229.1) | 1350<br>(612.4) | 2250<br>(1020.6) | 990<br>(449.1)  | 1450<br>(657.7)  |
| 24<br>(600)   | 48<br>(1221)                             | 50<br>(1275)                             | 41<br>(1064)                           | 43<br>(1102) | 23<br>(587)                            | 23<br>(602)                            | 17<br>(432)                           | 17<br>(432)                           | 23<br>(587)                            | 23<br>(602)                            | 17<br>(432)                           | 17<br>(432)                           | 63<br>(1603)                             | 64<br>(1634)                            | 430<br>(195)    | 790<br>(358.3) | 2100<br>(952.6) | 2340<br>(1061.4) | 1580<br>(716.7) | 2240<br>(1016.1) |

Note: Cover lifting lugs standard on sizes 10 and larger. Lifting lug dimensions are not included above. Dimensions shown are subject to change. Contact factory for certified prints when required.

T  
STRAINERS



# FT1 SERIES<sup>†</sup> FABRICATED T-STRAINER PRESSURE DROP - LIQUIDS

**Water Service, Clean Basket, 1/32" - 1/4" Perforated Screen\***

(SIZES 2" - 24")

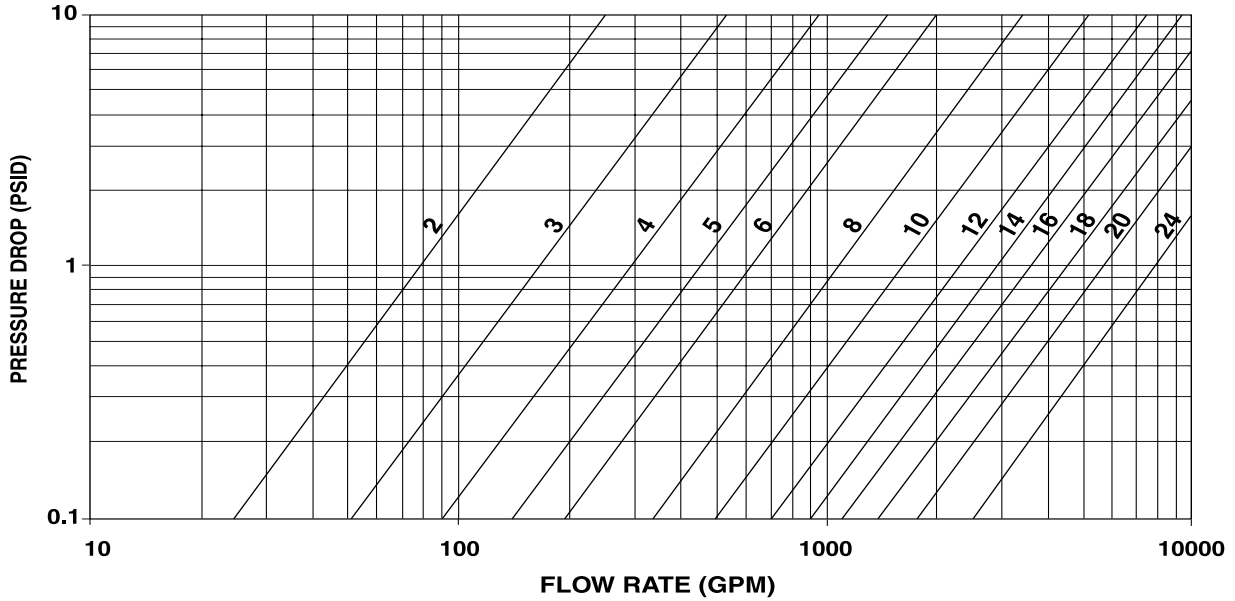

Notes:

1. Pressure drop curves are based on water flow with standard screens. See Screen Correction Factor Chart for correction factors to be used with other fluids and/or screen openings.

\* For Gas or Air service, consult Factory

<sup>†</sup> FT2 and FT3 - For Pressure Drop contact Factory.

Correction Factors for Clogged Screens Consult Factory

Steam Service Pressure Drop Consult Factory

Correction Factors for Other Viscous Liquids and/or Mesh Liners Consult Factory



# FT1 SERIES<sup>†</sup>

## FABRICATED T-STRAINER

### OPEN AREA RATIOS

#### with Standard Perforated Screen

For FT2, FT3 Open Area Ratios please contact SSI.

| Size | Perf. Diameter (inches) | Opening % | XH Pipe Inlet Area (in <sup>2</sup> ) | Gross Screen Area (in <sup>2</sup> ) | Free Screen Area (in <sup>2</sup> ) | Open Area Ratio (OAR) |
|------|-------------------------|-----------|---------------------------------------|--------------------------------------|-------------------------------------|-----------------------|
| 2    | 1/8                     | 40%       | 3.36                                  | 22                                   | 9                                   | 2.7                   |
| 2½   | 1/8                     | 40%       | 4.79                                  | 25                                   | 10                                  | 2.1                   |
| 3    | 1/8                     | 40%       | 7.39                                  | 40                                   | 16                                  | 2.2                   |
| 4    | 1/8                     | 40%       | 12.73                                 | 58                                   | 23                                  | 1.8                   |
| 5    | 1/8                     | 40%       | 20.01                                 | 82                                   | 33                                  | 1.6                   |
| 6    | 1/8                     | 40%       | 28.89                                 | 105                                  | 42                                  | 1.5                   |
| 8    | 1/8                     | 40%       | 50.03                                 | 167                                  | 67                                  | 1.3                   |
| 10   | 1/8                     | 40%       | 78.85                                 | 235                                  | 94                                  | 1.2                   |
| 12   | 1/8                     | 40%       | 113.10                                | 330                                  | 132                                 | 1.2                   |
| 14   | 3/16                    | 50%       | 140.50                                | 420                                  | 210                                 | 1.5                   |
| 16   | 3/16                    | 50%       | 185.66                                | 510                                  | 255                                 | 1.4                   |
| 18   | 3/16                    | 50%       | 237.10                                | 640                                  | 320                                 | 1.3                   |
| 20   | 3/16                    | 50%       | 294.83                                | 780                                  | 390                                 | 1.3                   |
| 24   | 3/16                    | 50%       | 429.13                                | 1,060                                | 530                                 | 1.2                   |

OAR = Free Screen Area / Inlet Area

Free Screen Area = Opening % x Gross Screen Area

Values shown are approximate. Consult factory for exact ratios.

<sup>†</sup> FT2 and FT3 - For Open Area Ratios contact Factory.

Other Screen Openings  
Page 138

Basket Burst Pressure  
Page 139





NOTES:

T  
STRAINERS

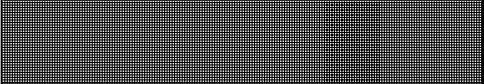
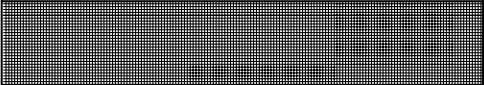
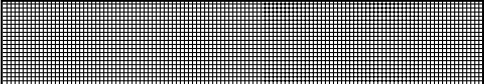
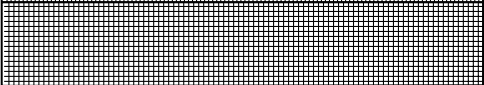
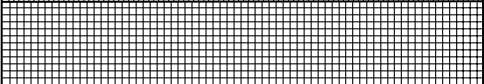
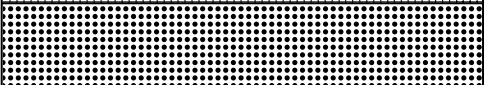
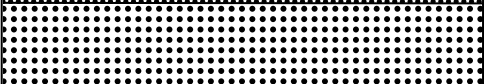
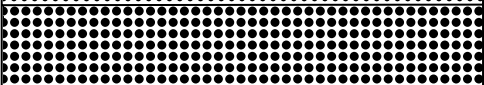
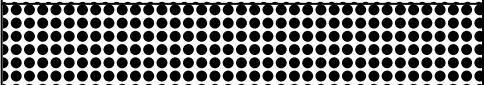

# T-STRAINER TECHNICAL INFORMATION

# SCREEN OPENINGS

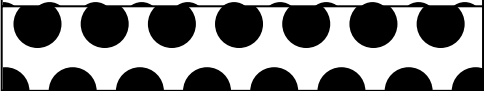
|   |  |
|---|--|
|    | 100 Mesh - 30% O.A.<br>0.006" Openings |
|    | 80 Mesh - 36% O.A.<br>0.008" Openings  |
|    | 60 Mesh - 38% O.A.<br>0.010" Openings  |
|    | 40 Mesh - 41% O.A.<br>0.016" Openings  |
|    | 30 Mesh - 45% O.A.<br>0.022" Openings  |
|    | 20 Mesh - 49% O.A.<br>0.035" Openings  |
|    | 0.027" Dia. - 23% O.A.                 |
|    | 0.033" Dia. - 28% O.A.                 |
|   | 3/64" Dia. - 36% O.A.                  |
|  | 1/16" Dia. - 37% O.A.                  |
|  | 3/32" Dia. - 39% O.A.                  |
|  | 1/8" Dia. - 40% O.A.                   |
|  | 5/32" Dia. - 58% O.A.                  |
|  | 3/16" Dia. - 50% O.A.                  |
|  | 1/4" Dia. - 40% O.A.                   |

## FACTORS TO CONSIDER

### 1 Purpose

If the strainer is being used for protection rather than direct filtration, standard screens will suffice in most applications.

### 2 Service

With services that require extremely sturdy screens, such as high pressure/temperature applications or services with high viscosities, perforated screens without mesh liners are recommended. If a mesh liner is required to obtain a certain level of filtration, then a trapped perf/mesh/perf combination is recommended.

### 3 Filtration Level

When choosing a perf. or a mesh/perf. combination, attention should be given to ensure overstraining does not occur. As a general rule, the specified level of filtration should be no smaller than half the size of the particle to be removed. If too fine a filtration is specified, the pressure drop through the strainer will increase very rapidly, possibly causing damage to the screen.

Screen openings other than those shown above are readily available. Various mesh sizes as fine as 5 micron and perforated plate as coarse as 1/2" Dia. are in inventory.

Screens are available in a wide range of materials. Screens of carbon steel, stainless steel (304, 316), alloy 20, monel 400, hastelloy C and titanium grade 2 are in inventory.

Custom manufactured screens are available upon request. Please consult factory.

# FT SERIES

## SCREEN BURST PRESSURE

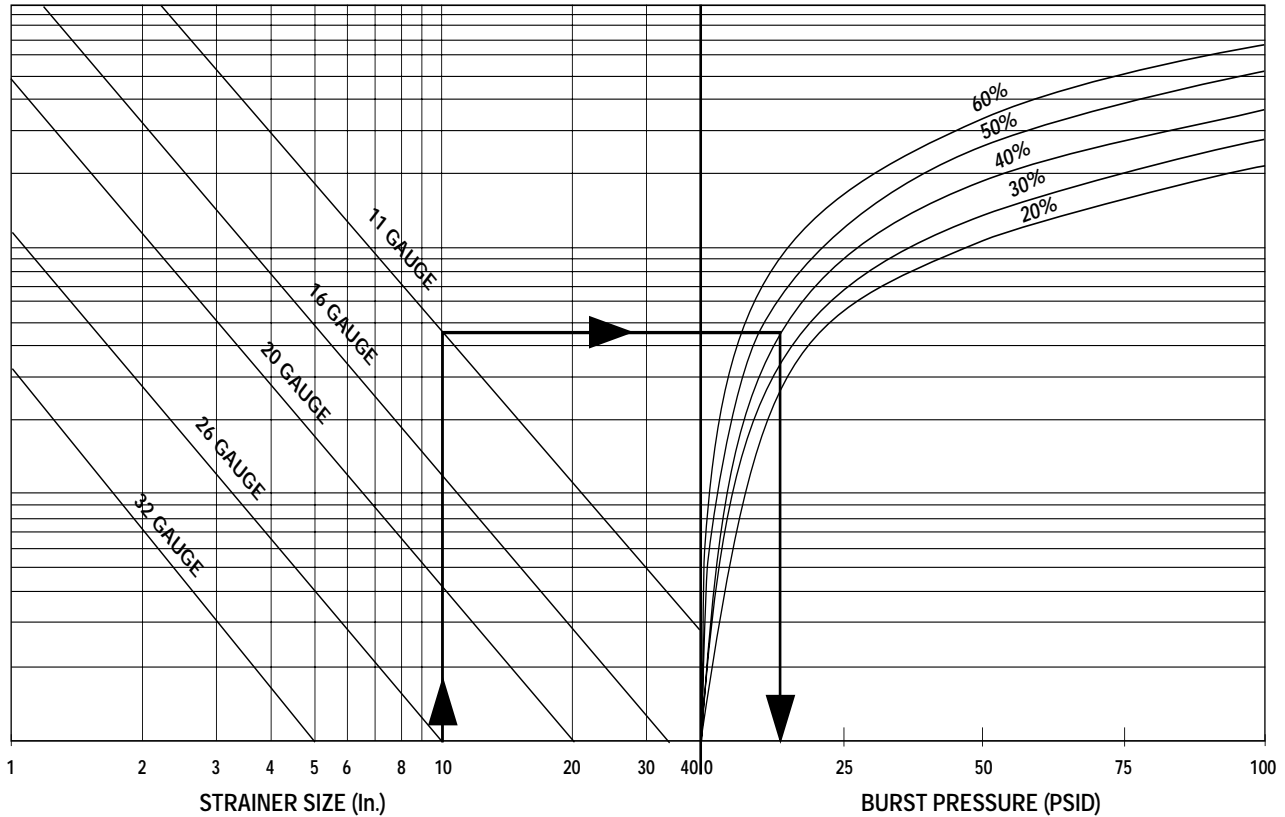

**Notes:**

1. The above chart is to be used for strainers manufactured from perforated plate and is based on the formula:

$$t = d \sqrt{\frac{0.3P}{S}}$$

- t = Thickness of perforated plate, in.
- d = Basket Diameter, in.
- P = Burst Pressure, psi
- S = Reduced allowable stress, psi

SOURCE: ASME Section VIII, Div. 1., UG-34.

2. The above chart is based on standard dimensions. Higher burst pressure ratings are available. Please contact factory.
3. The above chart is based on a screen material of stainless steel. No safety factor is incorporated. It is the responsibility of the user to determine an acceptable safety factor.
4. See Screen Openings Chart for % Open Area's of inventoried perforated plate.

**T**  
**STRAINERS**

|                                   |          |  |
|-----------------------------------|----------|--|
| <b>Example:</b>                   |          | A) Locate Strainer size.                                     |
| <b>Strainer Size:</b>             | 10"      | B) Follow vertical line to gauge thickness.                  |
| <b>Screen Thickness:</b>          | 11 gauge | C) Follow horizontal line to required perforation open area. |
| <b>Screen Material Open Area:</b> | 40%      | D) Follow vertical line downward to read burst pressure.     |
|                                   |          | E) Burst pressure equals 13 psid.                            |



# FT SERIES CHECKLIST

Please take the factors listed below into account when selecting a strainer. Kindly photocopy this page and fill out the pertinent information, to your best ability, so that we can recommend a Strainer to suit your specific requirements.

- |   |  |
|---|--|
| <p>1. Fluid to be strained _____</p> <p>2. Flow rate _____</p> <p>3. Density of fluid _____</p> <p>4. Viscosity of fluid _____</p> <p>5. Fluid working pressure _____<br/>Maximum pressure _____</p> <p>6. Fluid Working Temp. _____<br/>Maximum Temp. _____</p> <p>7. Preferred material of strainer construction _____</p> <p>8. Present Pipeline size &amp; material _____</p> <p>9. Nature of solids to be strained out _____</p> <p>10. Size of solids to be strained out _____<br/>Size of mesh or Perf. Req. _____</p> | <p>11. Clearance Limitation Above _____ Below _____<br/>Left side facing inlet _____ Right side facing inlet _____</p> <p>12. Maximum pressure drop with clean screen _____</p> <p>13. Expected cleaning frequency _____</p> <p>14. Any other information deemed relevant _____<br/>_____<br/>_____</p> <p>Name _____</p> <p>Company _____</p> <p>Address _____</p> <p>City/Town _____</p> <p>State _____ Zip Code _____</p> <p>Telephone ( _____ ) _____</p> <p>Fax ( _____ ) _____</p> |
|---|--|

# FT SERIES

## INSTALLATION AND MAINTENANCE INSTRUCTIONS

### STRAINER INSTALLATION INSTRUCTIONS

---

- Ensure all machined surfaces are free of defects and that the inside of the strainer is free of foreign objects.
- For horizontal and vertical pipelines, the strainer should be installed so that the blow-down drain connection is pointed downward.
- For flanged end strainers, the flange bolting should be tightened gradually in a back and forth clockwise motion. Threaded end strainers should use an appropriate sealant.
- Once installed, increase line pressure gradually and check for leakage around joints.
- If the strainer is supplied with a start-up screen, monitor pressure drop carefully.

### SCREEN REMOVAL INSTRUCTIONS

---

- Drain piping
- Vent line to relieve pressure.
- Loosen cover and open to access screen.
- Remove, clean and replace screen in original position (Note: In some instances, a high pressure water jet or steam may be required for effective cleaning)
- Inspect cover gasket for damage. If necessary, replace. (Note: If spiral wound gaskets have been used, they must be replaced and can not be used again).
- Tighten cover. The strainer is ready for line start-up.

CAUTION SHOULD BE TAKEN DUE TO POSSIBLE EMISSION OF PROCESS MATERIAL FROM PIPING. ALWAYS ENSURE NO LINE PRESSURE EXISTS WHEN OPENING COVER.

### MAINTENANCE INSTRUCTIONS

---

For maximum efficiency, determine the length of time it takes for the pressure drop to double that in the clean condition. Once the pressure drop reaches an unacceptable value, shut down line and follow the "Screen Removal Instructions" above. A

pressure gauge installed before and after the strainer in-line will indicate pressure loss due to clogging and may be used to determine when cleaning is required.

### TROUBLE SHOOTING GUIDES AND DIAGNOSTIC TECHNIQUES

---

- After pressurizing, inspect cover and other joints for leakage. Gasket replacement or cover tightening is necessary if leakage occurs.
- If the required filtration is not taking place, ensure the screen is installed in the correct position, that being flush to the screen seating surfaces.

**WARNING:** *This product operates in pipelines or with equipment that carries fluids and/or gasses at elevated temperatures and pressures. Caution should be taken to make sure that this equipment is installed correctly and inspected regularly. Caution should also be taken to protect personnel from fluid or gas leakage.*

NOTES:

T  
STRAINERS

