

## Applications

- Water and Liquid service
- Power Industry – Cooling water
- Pulp & Paper – Removing fibers
- Process Equipment – Protect equipment
- Metal & Mining – Quenching, blast furnace cooling

# Automatic Self-Cleaning Strainers

Pressures to 740 PSIG (51 BARG)

Temperatures to 400°F (204°C)

## FEATURES

- Standard and Custom Engineered Designs
- Complete Control Systems
- Intermittent or Continuous Mode options
- Individual or Skid System designs
- High Strength reverse rolled wedge wire screens

## MATERIALS

- Carbon Steel
- Stainless Steel
- Other materials upon request

## END CONNECTIONS

- Flat Faced Flanged
- Raised Faced Flanged
- Ring Joint Flanged
- Buttweld

## RATINGS

- ASME Class 150
- ASME Class 300

## SIZES

- 2" (50mm) to 36" (900 mm)

AUTO SELF-CLEANING  
STRAINERS

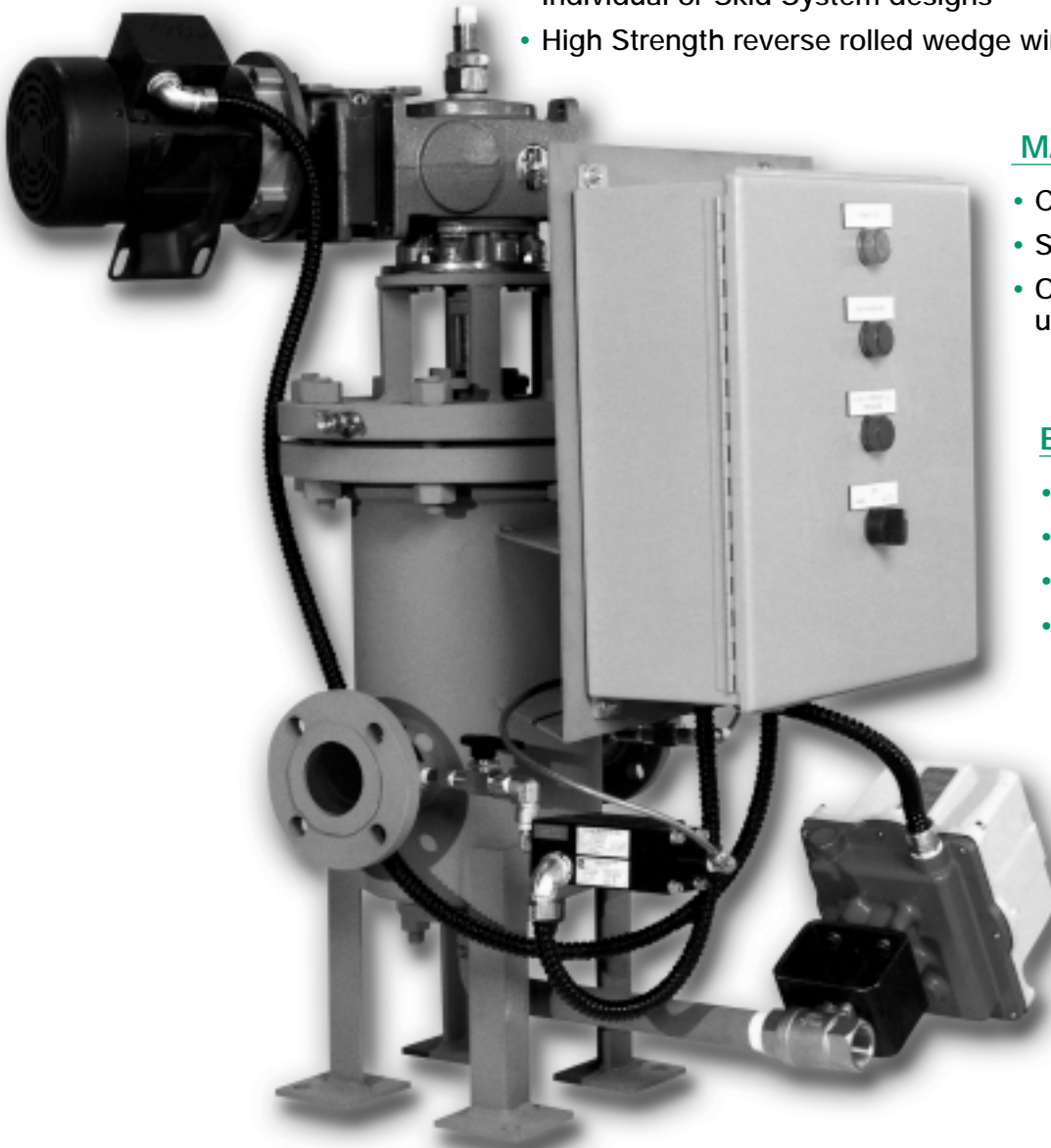

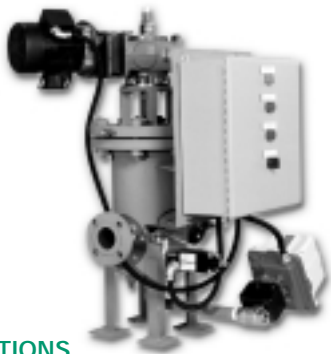

# FA SERIES FABRICATED AUTOMATIC SELF-CLEANING STRAINERS

Pressures to 740 PSIG (51 BARG)  
Temperatures to 400°F (204°C)

## APPLICATIONS

- Water and Liquid service
- Power Industry - cooling water
- Pulp & Paper - Removing fibers
- Process Equipment - Protect equipment
- Metal & Mining - Quenching, blast furnace cooling
- Water & Waste - Clean plant service water

## APPLICABLE CODES

- Designed/Manufactured to meet ASME B31.3 or ASME B31.4 and/or ASME Section VIII, Div. 1.
- Canadian Registration Numbers (CRN) upon request
- Welders certified to ASME Section IX
- ASME "U" Stamp upon request

**PRESSURE/TEMPERATURE CHART**  
ASME B16.34

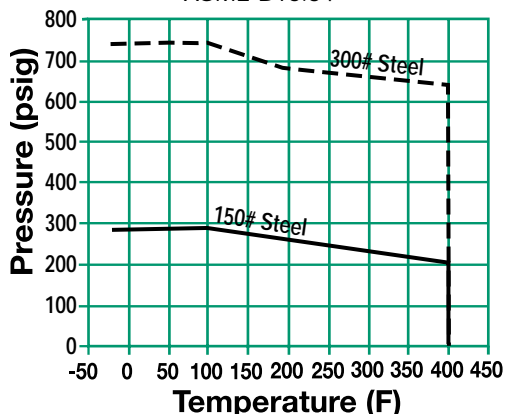

## FA Series Ordering Code

Model	Body Material	Inlet Size	Class	Connec- tion	Dash	Control Panel <sup>1</sup>	Wedge Wire <sup>2</sup>	Std. Slot Opening
<b>F A 1</b>	<b>C R</b>	<b>1</b>	<b>1</b>	<b>R</b>	<b>-</b>	<b>B</b>	<b>V</b>	<b>1</b>
1 2 3	4 5	6 7	8	9	10	11		

<p><b>Model</b> - Position 1 - 3</p> <p>FA1 - Inline, Side Backwash drain (Sizes 10" - 36")</p> <p>FA2 - Inline, Bottom Backwash drain (Sizes 2" - 8")</p> <p>FAZ - Custom Configuration</p>
<p><b>Body Material</b> - Position 4</p> <p>C - Carbon Steel</p> <p>V - 304 SS</p> <p>T - 316 SS</p> <p>M - Monel</p> <p>H - Hastelloy</p> <p>Z - Other</p>

<p><b>Inlet Size</b> - Position 5</p> <p>H - 2 U - 16</p> <p>J - 2½ V - 18</p> <p>K - 3 W - 20</p> <p>M - 4 X - 22</p> <p>N - 5 Y - 24</p> <p>P - 6 1 - 28</p> <p>Q - 8 2 - 30</p> <p>R - 10 3 - 36</p> <p>S - 12 4 - 40</p> <p>T - 14 Z - Other</p>
<p><b>Class</b> - Position 6</p> <p>1 - 150</p> <p>3 - 300</p> <p>Z - Other</p>

<p><b>Connection</b> - Position 7</p> <p>B - Butt Weld</p> <p>F - Flat Face Flange</p> <p>J - Ring Joint Flange</p> <p>R - Raised Face Flange</p> <p>Z - Other</p>
<p><b>Dash</b> - Position 8</p>
<p><b>Control Panel<sup>1</sup></b> - Position 9</p> <p>A - None</p> <p>C - 1-phase, 110/120 VAC</p> <p>E - 3-phase, 460/or 80 VAC</p> <p>F - 3-phase, 575 VAC</p> <p>Z - Other</p>

<p><b>Screen - Wedge Wire<sup>2</sup></b> -</p> <p>Position 10</p> <p>V - 304SS</p> <p>T - 316SS</p> <p>M - Monel</p> <p>H - Hastelloy</p> <p>Z - Other</p>
<p><b>Standard Slot Opening</b> -</p> <p>Position 11</p> <p>1 - .156"</p> <p>2 - .125" (1/8")</p> <p>3 - .094"</p> <p>4 - .063" (1/16")</p> <p>7 - .031" (1/32")</p> <p>8 - .020"</p> <p>9 - .015"</p> <p>A - .010"</p> <p>B - .005"</p> <p>C - .003"</p> <p>Z - Other</p>

- Standard and Custom Engineered Designs
- Reverse rolled wedge wire screen for high strength
- Proportioned outer annulus decreases pressure drop
- Low inertia backwash assembly increases efficiency and minimizes power requirements
- Fail safe mode to prevent internal damage from jamming by large debris
- Large inspection port allows for inspection and removal of settled debris

## MODELS

- FA1 - Inline, side backwash drain, (10" - 36")
- FA2 - Inline, bottom backwash drain, (2" - 8")
- FAZ - Custom Configuration

## OPTIONS (Consult factory)

- Other materials, sizes and/or configurations
- Other screen sizes/materials- See page 105
- "U" stamped vessels
- External/Internal coatings
- Custom control panels and wiring per customer requests. See page 104
- Adjustable timer and differential pressure override switch for automatic intermittent control mode
- Continuous on/off control mode
- Customer requested control valves and tubing
- Skid mounted or free standing designs
- Contact Factory for other Options

1. For standard control system components see page 105. For all other please consult factory.

2. Standard Screen material is 304SS

For any variations, use the part numbering system above but clearly indicate the additional requirements.

# FA1 SERIES FABRICATED AUTOMATIC SELF-CLEANING STRAINERS

## SPECIFICATION

Strainer shall be designed and manufactured to meet ASME B31.3 or ASME B31.4 and/or ASME Section VIII, Div I. The strainer body shall be 1-piece construction, fabricated steel or other specified material and inlet/outlet connections shall be In-Line Design with a side backwash drain. The control system shall be capable of automatically controlling and monitoring the strainer's operation. The strainer shall have a fail-safe mode to prevent internal damage from jamming of strainer shaft caused by large debris. The strainer shall have a Nema 4 control panel with an actuated valve to provide control of the backwash flow. The screen shall be size \_\_\_\_\_ wedge wire construction. The strainer shall have an inlet size of \_\_\_\_\_ and open area ratio of \_\_\_\_\_. The Automatic Strainer shall be SSI FA1\_\_\_\_\_.

## MATERIALS OF CONSTRUCTION\*-

(Carbon Steel Shown\*)

Body.....SA53 Gr B or SA106-B  
 Flanges.....SA105  
 Nozzles.....SA53 Gr B or SA106-B  
 Heads.....SA234 WPB  
 Screen<sup>1</sup>.....SA240-304 SS  
 Backwash Arm.....SA240-304 SS  
 Bearing<sup>1</sup>.....Varies upon temperature  
 Gasket - Cover<sup>1</sup>.....Red rubber or BlueGuard  
 Gasket - Basket<sup>1</sup>.....Gum Rubber or Viton  
 Gasket - Bearing<sup>1</sup>.....Gum Rubber or Viton  
 Packing<sup>1</sup>.....TFE or Cotton Nitrile  
 Stud.....SA 193-B7  
 Nut.....SA 194-2H

\* Other Materials Available. Consult Factory.

1. Recommended Spare Parts

Materials specification will change dependent on customer design – contact factory for certified prints.

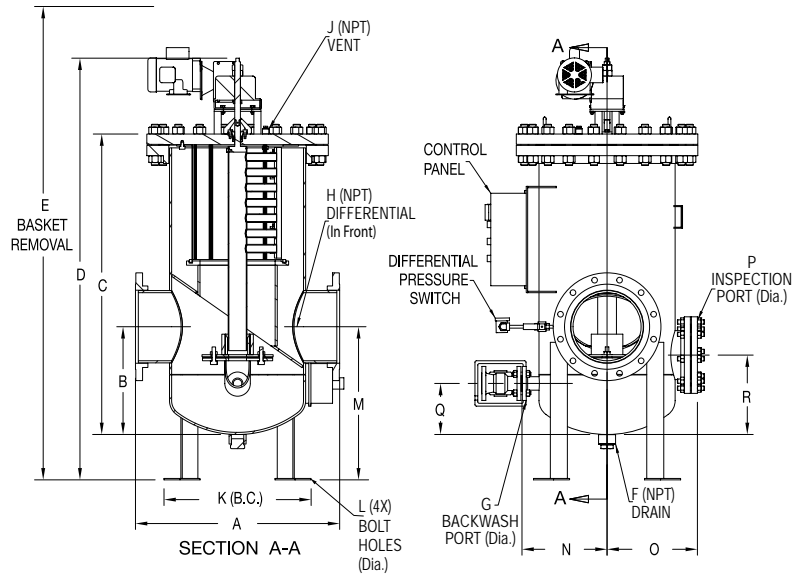

Connections: 10" - 36"  
RF, FF, RTJ or Buttweld

## SCREEN OPENINGS\*

SIZE	STANDARD SCREEN	STANDARD MATERIALS
10"-36"	.125" (1/8")	304SS Wedge Wire

\* See other screen sizes on page 105

## MINIMUM INLET PRESSURE (I/O Differential)

SIZE	PRESSURE
10"-36"	20 PSID

## FA1 DIMENSIONS inches (mm) AND WEIGHTS pounds (kg)

150# Class flanges shown (For 300# dimensions and weights-contact factory)

INLET SIZE	BODY SIZE	A	B	C	D	E	F (NPT)	G (Dia.)	H (NPT)	J (NPT)	K (B.C.)	L (Dia.)	M	N	O	P (Dia.)	Q	R	WEIGHT		
																			DRY	WET	COVER
10 (250)	24 (600)	36 (914)	19 (483)	53 (1346)	74% (1889)	111 (2819)	2 (2)	2 (50)	1/2 (1/2)	1/2 (1/2)	30% (767)	7/8 (22)	27 (686)	15 (381)	16 (406)	8 (203)	9 (229)	14 (356)	1200 (544)	1950 (884)	415 (188)
12 (300)	24 (600)	36 (914)	19 (483)	53 (1346)	74% (1889)	111 (2819)	2 (2)	2 (50)	1/2 (1/2)	1/2 (1/2)	30% (767)	7/8 (22)	27 (686)	15 (381)	16 (406)	8 (203)	9 (229)	14 (356)	1200 (544)	1950 (884)	415 (188)
14 (350)	26 (660)	46 (1168)	25 (635)	60 (1524)	81% (2067)	120 (3048)	2 (2)	3 (80)	1/2 (1/2)	1/2 (1/2)	32% (817)	7/8 (22)	33 (838)	19 (483)	20 (508)	8 (203)	15 (381)	18 (457)	1700 (771)	3000 (1361)	363 (165)
16 (400)	30 (760)	46 (1168)	26 (660)	66 (1676)	87% (2219)	127 (3226)	2 (2)	3 (80)	1/2 (1/2)	1/2 (1/2)	37% (962)	1 (25)	34 (864)	19 (483)	20 (508)	8 (203)	15 (381)	18 (457)	1800 (816)	3100 (1406)	530 (240)
18 (50)	30 (760)	50 (1270)	27 (686)	73 (1854)	94% (2397)	133 (3378)	2 (2)	3 (80)	1/2 (1/2)	1/2 (1/2)	37% (962)	1 (25)	35 (889)	22 (559)	23 (584)	8 (203)	15 (381)	18 (457)	2600 (1179)	4900 (2222)	530 (240)
20 (500)	36 (910)	50 (1270)	30 (762)	79 (2007)	100% (2550)	144 (3658)	2 (2)	4 (100)	1/2 (1/2)	1/2 (1/2)	44% (1121)	1 (25)	38 (965)	23 (584)	23 (584)	12 (305)	16 (406)	20 (508)	2900 (1315)	5400 (2449)	883 (400)
24 (600)	40 (1010)	64 (1626)	32 (813)	87 (2210)	108% (2753)	157 (3988)	3 (3)	4 (100)	1/2 (1/2)	1/2 (1/2)	51% (1311)	1% (35)	40 (1016)	29 (737)	30 (762)	12 (305)	16 (406)	22 (559)	4700 (2132)	9700 (4399)	1205 (546)
30 (760)	48 (1210)	78 (1981)	45 (1143)	117 (2972)	138% (3515)	200 (5080)	3 (3)	4 (100)	1/2 (1/2)	1/2 (1/2)	59% (1521)	1% (35)	53 (1346)	35 (889)	36 (914)	12 (305)	22 (559)	34 (864)	8600 (3900)	14400 (6531)	2015 (914)
36 (910)	58 (1470)	96 (2438)	53 (1346)	140 (3556)	161% (4099)	234 (5944)	3 (3)	5 (125)	1/2 (1/2)	1/2 (1/2)	69% (1775)	1% (35)	61 (1549)	44 (1118)	46 (1168)	12 (305)	24 (610)	40 (1016)	14800 (6712)	32000 (14512)	3492 (1584)

\*Dimensions shown are subject to change. Contact factory for certified prints when required.

# FA2 SERIES FABRICATED AUTOMATIC SELF-CLEANING STRAINERS

## SPECIFICATION

Strainer shall be designed and manufactured to meet ASME B31.3 or ASME B31.4 and/or ASME Section VIII, Div I. The strainer body shall be 1-piece construction, fabricated steel or other specified material and inlet/outlet connections shall be In-Line Design with a bottom backwash drain. The control system shall be capable of automatically controlling and monitoring the strainer's operation. The strainer shall have a fail-safe mode to prevent internal damage from jamming of strainer shaft caused by large debris. The strainer shall have a Nema 4 control panel with an actuated valve to provide control of the backwash flow. The screen shall be size \_\_\_\_\_ wedge wire construction. The strainer shall have an inlet size of \_\_\_\_\_ and open area ratio of \_\_\_\_\_. The Automatic Strainer shall be SSI FA2\_\_\_\_\_.

## MATERIALS OF CONSTRUCTION\*-

(Carbon Steel Shown\*)

Body.....SA53 Gr B or SA106-B  
Flanges.....SA105  
Nozzles.....SA53 Gr B or SA106-B  
Heads .....SA234 WPB  
Screen<sup>1</sup> .....SA240-304 SS  
Backwash Arm .....SA240-304 SS  
Bearing<sup>1</sup> .....Varies upon temperature  
Gasket - Cover<sup>1</sup> .....Red rubber or BlueGuard  
Gasket - Basket<sup>1</sup> .....Gum Rubber or Viton  
Gasket - Bearing<sup>1</sup> .....Red Rubber or BlueGuard  
Packing<sup>1</sup> .....TFE or Cotton Nitrile  
Stud.....SA 193-B7  
Nut .....SA 194-2H

\* Other Materials Available. Consult Factory

1. Recommended Spare Parts

Materials specification will change dependent on customer design – contact factory for certified prints.

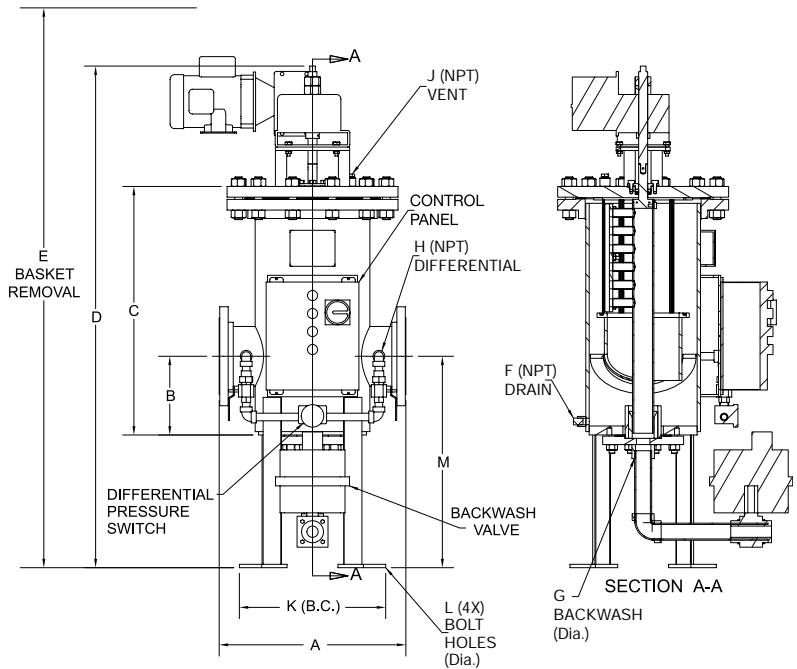

Connections: 2" -8"  
RF, FF, RTJ or Buttweld

## SCREEN OPENINGS\*

SIZE	STANDARD SCREEN	STANDARD MATERIALS
2" -8"	.125" (1/8")	304SS Wedge Wire

\* See other screen sizes on page 105

## MINIMUM INLET PRESSURE (I/O Differential)

SIZE	PRESSURE
2" -8"	20 PSID

## FA2 DIMENSIONS inches (mm) AND WEIGHTS pounds (kg) 150# Class flanges shown (For 300# dimensions and weights-contact factory)

INLET SIZE	BODY SIZE	A	B	C	D	E	F (NPT)	G (Dia.)	H (NPT)	J (NPT)	K (B.C.)	L (Dia.)	M	WEIGHT		
														DRY	WET	COVER
2 (50)	8 (200)	16 (406)	5 (127)	17½ (441)	38¾ (984)	60 (1524)	1/2 (1/2)	1 (1)	1/2 (1/2)	1/2 (1/2)	13¾ (349)	9/16 (14)	13 (330)	310 (141)	329 (149)	50 (23)
3 (80)	8 (200)	16 (406)	5 (127)	17½ (441)	38¾ (984)	62 (1575)	1/2 (1/2)	1 (1)	1/2 (1/2)	1/2 (1/2)	13¾ (349)	9/16 (14)	13 (330)	320 (145)	340 (154)	50 (23)
4 (100)	10 (250)	18 (457)	8¾ (222)	23½ (606)	52 (1321)	76 (1930)	1/2 (1/2)	1 (1)	1/2 (1/2)	1/2 (1/2)	16 (406)	9/16 (14)	23½ (597)	430 (195)	490 (222)	72 (33)
6 (150)	12 (300)	20¾ (527)	8¾ (222)	29¾ (752)	57¾ (1467)	86 (2184)	1/2 (1/2)	1½ (1½)	1/2 (1/2)	1/2 (1/2)	18 (457)	9/16 (14)	23½ (597)	560 (254)	670 (304)	103 (47)
8 (200)	16 (400)	24 (610)	8¾ (222)	38 (965)	65¾ (1670)	100 (2540)	1/2 (1/2)	1½ (1½)	1/2 (1/2)	1/2 (1/2)	21¾ (541)	9/16 (14)	23½ (597)	875 (397)	1120 (508)	176 (80)

\*Dimensions shown are subject to change. Contact factory for certified prints when required.

# FA SERIES FABRICATED AUTOMATIC SELF-CLEANING STRAINERS GENERAL OPERATION

The Spence Strainer Fabricated Automatic Self-Cleaning Strainer utilizes the latest technology in backwash strainer design.

The strainer cleans itself using a backwash system which is continuous and/or controlled by an automatic control system. A tubular backwash assembly slowly

rotates in close contact with the internal wedge-wire straining element, isolating only a small portion of the element at any given time. Debris is removed by a backwash flow which carries unwanted debris away from the internal element and out of the strainer. The operation is detailed as follows:

## Operation

1. The unfiltered fluid enters the strainer inlet into the lower single chamber. This chamber acts to both slow the fluid prior to straining and to collect any settled debris.
2. The fluid passes upward and then radially outward through the wedge wire straining element. Debris larger than the wedge wire slot size is unable to pass through the straining element.
3. The clean fluid continues through the properly proportioned flow path and out the strainer outlet.
4. The strainer is controlled by an electrical panel, an actuated valve and a differential pressure switch. The cleaning cycle can be initiated manually or automatically by a timer with a differential pressure override.
5. When backwashing is initiated the motor begins to slowly turn the backwash assembly (approximately 2 rpm) and simultaneously the backwash valve is opened. The differential pressure between the line pressure and atmosphere is the driving force behind the backwashing process.
6. The hollow tubular backwash assembly, which is piped to the atmosphere, slowly rotates in close contact with the internal straining element. Only a small portion of the screen is isolated allowing for uninterrupted operation of the strainer during the backwashing process.
7. The pressure differential causes a large reverse flow across the screen and into the tubular backwash assembly. The change in velocity of the fluid entering the backwash assembly creates a vacuum and suction, cleaning the strainer element from the inside. A port shoe, interconnecting the tubular backwash assembly, optimizes the effectiveness of this backwash jet stream.

### BACKWASH ASSEMBLY / STRAINING ELEMENT INTERFACE

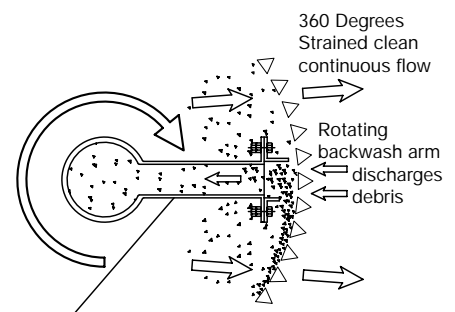

Atmospheric pressure ensures efficiency and minimizes power requirements during the backwash cycle.

### STRAINING CYCLE

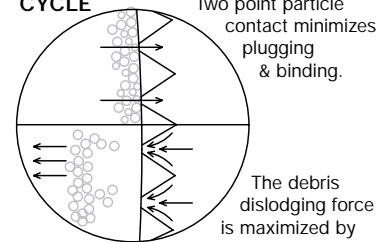

### BACKWASH CYCLE

8. Unwanted debris is carried into the full port backwash manifold and out the backwash connection. During the whole operation the flow remains uninterrupted keeping flow loss at a minimum.
9. Upon completion of the cycle, the control panel initiates turning the motor off and simultaneously closing the backwash valve.

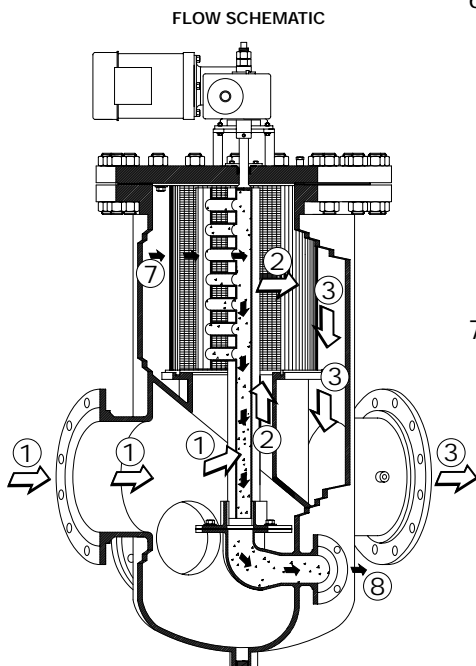

# FA SERIES FABRICATED AUTOMATIC SELF-CLEANING STRAINERS CONTROL SYSTEMS

The Spence Strainer control panels are designed for simple and reliable operation. The design allows for quick and easy field adjustments as required by the service conditions.

The FA Series strainers are manufactured complete with our standard control systems. Optional custom designs to meet specific customer and/or service requirements can be furnished.

Standard Control System Components –  
contact factory for other options

- Nema 4X rated panel box – UL/CSA approved
- Carbon steel, phosphate coated w/grey polyester powder coated panel box
- Adjustable timer  
(1-10 min on time, 10 min – 10 hr off time)
- Aluminum Nema 4 differential pressure override switch (0-15 psid)
- Control relay for backwash valve activation
- Three Indication panel lights – Power on, Backwash Valve Open, High Differential Pressure
- Selector Switch for Hand(On)/Off/Auto service
- Motor starters with Auxiliary contact
- Terminal block for external connections
- TEFC motor 110/120V, single phase 60Hz, 1/3 Hp
- 110/120 VAC input
- Carbon steel electrically actuated ball valve for backwash (110/120 VAC/60 HZ) – Nema 4 actuator

## Modes of Operation

The selector switch allows the customer to easily change between three modes: OFF, AUTO (Automatic Intermittent), or HAND (Continuous).

Automatic Intermittent (AUTO) – When the selector switch is in the AUTO position the strainer operates with the adjustable timer. An authorized operator can adjust the OFF time setting (the time after which it will initiate backwash – 10 min to 10 hour cycle) and ON time setting (the time interval for which it will keep backwash system ON – 1 to 10 min cycle) by adjusting the timer.

The differential pressure switch should be set at 2 psig over the anticipated clean pressure drop. An authorized operator can adjust OFF time setting on the differential pressure switch (the differential pressure at which it will initiate backwash – range 0 – 15 psid). This switch will override the time cycle and initiate backwash should

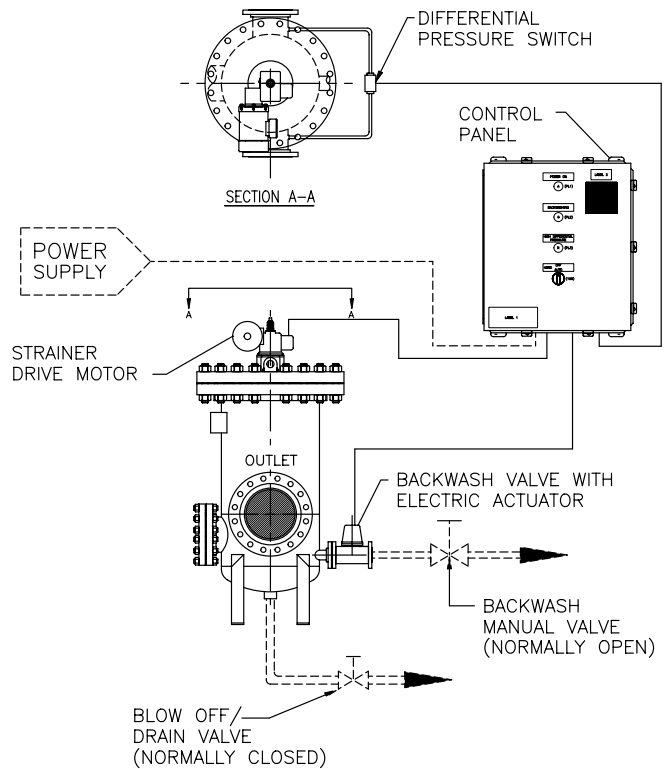

the differential pressure rise above the programmed setting. After the differential pressure has been satisfied, the strainer will continue cleaning for 60 seconds beyond that point.

The settings are done depending on the quantity of debris collected and limiting value of the differential pressure. Experience will dictate the optimal settings for the timers.

Continuous (HAND) – When the selector switch is in the HAND position the strainer will operate in a continuous mode. In this mode the strainer will backwash continuously with the backwash valve open and the drive motor running. The continuous backwash mode may be desirable or necessary if the installation experiences high solid loadings.

## Backwash Valve

Electrically actuated ball valves suitable for water service are standard on all FA Control Systems. Contact factory for other options. Standard sizes of backwash valves are as follows:

Strainer Inlet/Outlet Size	Drain Valve Size
2" - 4"	1"
6" - 8"	1½"
10" - 12"	2"
14" - 18"	3"
20" - 36"	4"

# FA SERIES FABRICATED AUTOMATIC SELF-CLEANING STRAINERS

## PRESSURE DROP - LIQUIDS

Water Service, Clean Basket .010" to .156" Slotted Wedge Wire\*1  
(Sizes 2" - 36")

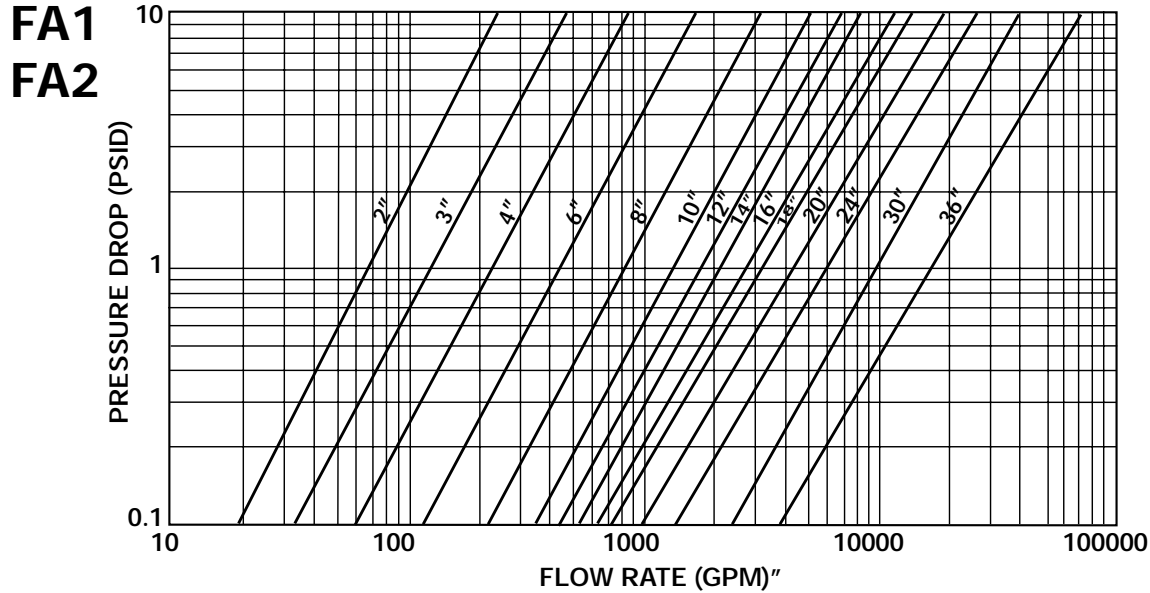

\* For other fluids and/or special conditions, consult factory  
1. For screen sizes below .010" contact factory.

AUTO SELF-CLEANING  
STRAINERS

## SCREEN SIZES AND OPEN AREA RATIOS

Slot Opening (inches)	Micron (Equivalent)	Mesh (Equivalent)	Open Area %
.156	3962	N/A	71
.125 (1/8)	3175	N/A	67
.094	2350	N/A	61
.063 (1/16)	1600	10	51
.031 (1/32)	775	20	34
.020	500	30	25
.015	381	40	20
.010	254	60	14.3
.005	127	120	7.7
.003	75	200	4.7

\* Contact factory for other screen sizes

*For Installation and Maintenance Instructions – please contact the factory*

# FA SERIES

## FABRICATED AUTOMATIC SELF-CLEANING STRAINER

### Sizing and Selection Guidelines and Worksheet

The information below is the standard FA Series operating parameters and guidelines. Custom engineered designs are available on customer request. Please consult the factory for requirements outside of the normal operating parameters and guidelines below.

1. The strainer meets the design pressure and temperature of the required service application.
2. Determine the backwash discharge pressure, recommend backwash to atmospheric pressure.
3. Minimum inlet pressure (or differential pressure between inlet pressure and backwash discharge pressure) is 20 psid.
4. Review the quantity and type of debris to be removed. Suspended solids should not exceed 200 PPM or 2% of volume.
5. Select the correct screen size and open area for the application *(See page 105)*
6. Determine your acceptable maximum pressure drop across the strainer and review with the FA Series pressure drop curves *on page 105*
7. Strainer inlet velocity should be 6 to 10 feet/min.

Sizing and Selection Worksheet – (Please submit with order and quotation requests)

#### A. Sizing Requirements

1. Fluid Service: \_\_\_\_\_
2. Specific Gravity (i.e water =1): \_\_\_\_\_
3. Viscosity (CPS / SSU) \_\_\_\_\_
4. Inlet Pressure (PSI): Min \_\_\_\_\_; Max \_\_\_\_\_; Operating \_\_\_\_\_
5. Temperature (F): Min \_\_\_\_\_; Max \_\_\_\_\_; Operating \_\_\_\_\_
6. Flow Rate (GPM): Min \_\_\_\_\_; Max \_\_\_\_\_; Operating \_\_\_\_\_
7. Max allowable Pressure drop (PSI): Clean \_\_\_\_\_; Dirty \_\_\_\_\_
8. Backwash pressure (PSI) \_\_\_\_\_ (enter 0 for atmospheric)
9. Solids to be removed:  Hard;  Soft;  Fibrous  Sticky
10. Solid Concentration (PPM): \_\_\_\_\_
11. Solid Size: Inches \_\_\_\_\_ or Microns \_\_\_\_\_
12. Special : \_\_\_\_\_

#### B. Strainer Construction

1. Design Code:  ASME VIII Non Code;  ASME VIII Code "U" Stamp;  Other \_\_\_\_\_
2. Inlet Size (inches): \_\_\_\_\_
3. Outlet Size (inches): \_\_\_\_\_
4. Body Material:  CS;  304SS;  316SS  Other \_\_\_\_\_
5. End Connections:  125# FF Flanged;  150# RF Flanged;  Other \_\_\_\_\_
6. Basket Material:  304SS;  316SS  Other \_\_\_\_\_
7. Screen Size (Slot Size): \_\_\_\_\_
8. Special: \_\_\_\_\_

#### C. Controls

1. Panel:  Nema 4;  Other \_\_\_\_\_
2. Motor power supply (V, PH, Hz):  110/120V, 1PH, 60Hz;  Other \_\_\_\_\_
3. Special: \_\_\_\_\_

D. Other Special Requirements: \_\_\_\_\_

800-926-7110 • Fax: 845-778-1345 • [www.spencestrainers.com](http://www.spencestrainers.com)

