

DRAIN-AIR & MINI-DRAINS



Condensate Removal from Air Systems
Pressures To 600 PSIG (41.4 barg)
Temperatures to 220°F (104°C)

Automatic and Positive Drain — Effectively removes condensate from compressed air systems with minimum air loss and rapid shutoff on no load conditions.

Reliable — Only one moving part.

Low Maintenance Cost — No adjustments necessary. Replaceable cartridge for in line repair and/or cleaning.

Long Service Life — Stainless Steel internals.

Freezeproof — Will not freeze when installed in vertical position with muffler removed.

Quiet Operation — Meets OSHA noise standards.

Simplifies Startup — No need to drain air lines through manual valves or petcocks. Top performance is reached without waiting for system to purge.

Sized for Most Applications — Drain-Air available in 3/8" and 1/2"; Mini-Drain available in 1/8" and 3/8".

APPLICATIONS

Drain-Air

- Air Header Drainage (pocket risers, end of line)
- Air Station or Location where petcock is used for blowdown, collecting wells, separators.

Mini-Drain

- Pneumatic Tools
- Air Filters
- Pneumatic Valves

Canadian Registration # OE0591.9C

MODELS

- **Drain Air**—Forged body w/SS internal mechanism & nylon muffler
- **Mini Drain**—All SS integral body w/nylon muffler

Note: Pneumatic mufflers are available separately.

OPERATION

A simple disc is used with no linkage or close fitting parts to eliminate problems found in ordinary small float or piston-operated devices used in drip legs on air lines. Disc will lift off seat on a periodic time cycle, allowing moisture to be discharged and atomized through the muffler. Positive action of the disc assures reliable condensate removal with

minimum loss of air and rapid shutoff on no load condition. Intermittent discharges atomize condensate to avoid messy accumulations produced by other devices. Highly effective, specially designed muffler eliminates noise and diffuses moisture so that discharge drain piping is usually unnecessary. Freeze proof when mounted in vertical position with outlet facing down and muffler removed.

DRAIN-AIR & MINI-DRAINS

SPECIFICATION

The liquid drain trap shall be of thermodynamic design with screwed NPT connections. Internal mechanism shall be stainless steel with hardened working surfaces. A pneumatic muffler shall be employed to reduce exhaust sound pressure level.

MAXIMUM OPERATING CONDITIONS

PMO: Max. Operating Pressure	600 psig	(41.4 barg)
TMO: Max. Operating Temperature	220°F	(104°C)
PMA: Max. Allowable Pressure	600 psig	(41.4 barg)
TMA: Max. Allowable Temperature	800°F	(426°C)

MATERIALS OF CONSTRUCTION

DRAIN-AIR

- Body & Cover:ASTM A105 Forged Steel
- Celtron® Cartridge:416 Stainless Steel
w/hardened disc & seat
- Bolts:High temperature alloy
- Cover Gasket:347 Stainless Spiral-wound
w/graphite filler
- Integral Strainer:304 Stainless Steel
- Muffler:Nylon Housing, Aluminum Screen
- Connections:3/8"-1/2" NPT

MINI-DRAIN

- Cap, Seat & Disc:416 Stainless, Hardened
- Muffler:Nylon Housing, Aluminum Screen

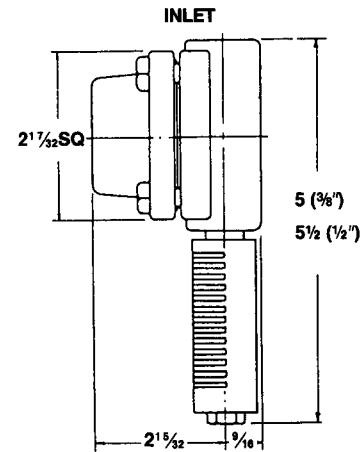

3/8" & 1/2" DRAIN-AIR
2.3 LBS.

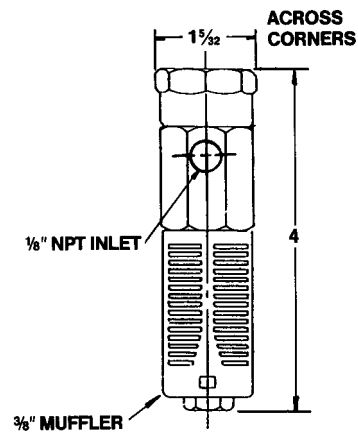

1/8" MINI-DRAIN
.9 LBS.

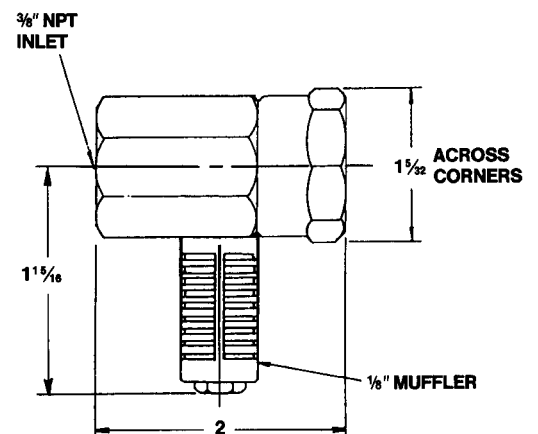

3/8" MINI-DRAIN
.9 LBS.

Connections: 1/8"-3/8" NPT

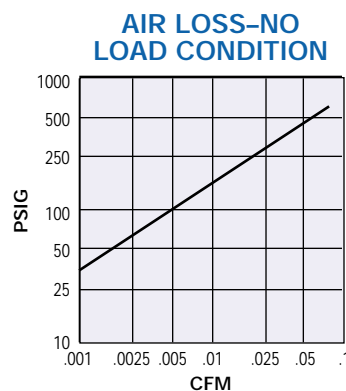
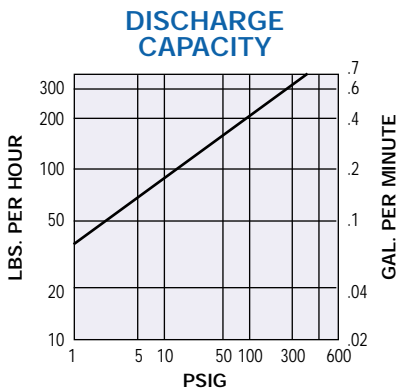

TAV SERIES

THERMOSTATIC AIR VENT

Pressures To 650 PSIG (44.8 barg)
Temperatures to 750°F (400°C)



Sealed Stainless Steel Body — Lightweight, compact and corrosion resistant. No bolts or gaskets. Eliminates body leaks.

Self Centering Valve — Leak tight shutoff. Improved energy savings. Assembly of actuator and valve to impingement plate allows valve to self-align with center of valve seat orifice. Provides long lasting valve and seat.

Temperature Sensitive Actuators — One moving part. Stainless Steel, fail open, welded actuator for maximum corrosion, thermal and hydraulic shock resistance.

Thermal and Hydraulic Shock Resistant — Impingement plate plus welded construction prevent damage to actuator.

Hardened Stainless Steel Valve and Seat — Long life. Lapped as a matched set for steam tight seal.

Inexpensive — Low initial cost.

Maintenance Free — Sealed unit. Replacement traps cost less than repair of more expensive in-line repairable vents.

Directional Discharge — Pipe thread erosion prevented by directing discharge to center of pipe.

Guaranteed — Guaranteed for 3 years against defects in materials or workmanship.

APPLICATIONS

- Platen Presses
- Plating Tanks
- Sterilizers
- Tire Presses
- Cooking Equipment
- Laundry Equipment
- Other Process Equipment

Canadian Registration # OE0591.9C

MODELS

- TAV—High capacity w/welded SS actuator

OPERATION

Thermal actuator is filled at its free length with a liquid having a lower boiling point than water. As assembled, valve is normally open. On startup, air passes through vent. As air is eliminated, hot steam reaches vent and the thermal actuator fill vaporizes to a pressure higher than line pressure. This forces

valve into seat orifice to prevent any further flow. Should more air collect, it takes heat from the actuator, lowering internal pressure. Line pressure will then compress thermal actuator to open valve and discharge air. Valve lift automatically adjusts to variations.

TAV SERIES THERMOSTATIC AIR VENT

SPECIFICATION

Air vent shall be of balanced pressure design stainless steel welded actuator capable of discharging air within 35°F of saturated temperature. Thermostatic actuator shall employ a conical valve lapped in matched sets with the seat ring assuring tight shut off. Vent shall be stainless steel bodied suitable for pressures to 650 psig and available in 3/8" through 1" NPT or socketweld.

MAXIMUM OPERATING CONDITIONS

PMO: Max. Operating Pressure	650 psig	(44.8 barg)
TMO: Max. Operating Temperature	650°F	(343°C)
PMA: Max. Allowable Pressure	650 psig	(44.8 barg)
TMA: Max. Allowable Temperature	750°F	(400°C)

MATERIALS OF CONSTRUCTION

Body & Cover:ASTM A351 Grade CF3M (316L)
 Actuator:Welded Stainless Steel
 Valve & Seat:Hardened 416 Stainless Steel

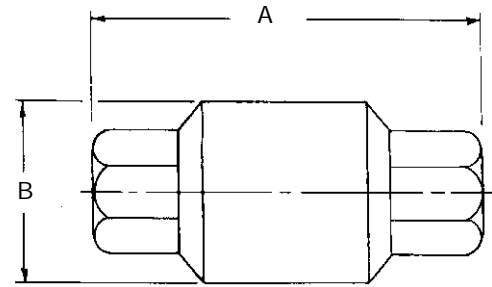

3/8" - 3/4" BODY

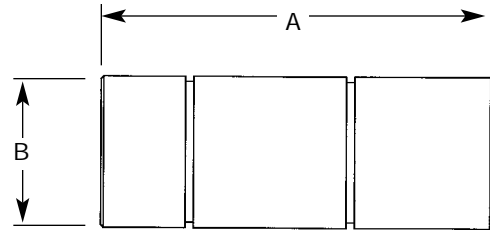

1" BODY

Connections:
3/8" - 1" NPT or socketweld

NPT or Socket weld	inches (mm)		Weight Lbs. (kg)
	A	B	
3/8, 1/2"	3 ³ / ₄ (95)	1 ³ / ₄ (44)	1.1 (0.5)
3/4"	3 ¹⁵ / ₁₆ (100)	1 ³ / ₄ (44)	1.2 (0.54)
1"	4 ³ / ₈ (111)	1 ³ / ₄ (44)	1.6 (0.73)

Air Capacity—SCFM for 14.7 PSIA @ 60°F (dm³/s)

Vent	Orifice Inch (mm)	Inlet Pressure (barg)														
		10 (0.7)	50 (3.5)	100 (6.9)	125 (8.62)	150 (10.3)	200 (13.8)	250 (17.2)	300 (20.7)	350 (24.1)	400 (27.6)	450 (31.0)	500 (34.5)	550 (37.9)	600 (41.4)	650 (44.8)
TAV	5/16 (8)	33 (16)	34 (20)	156 (74)	192 (91)	230 (109)	300 (142)	370 (175)	440 (208)	510 (241)	580 (274)	650 (307)	720 (340)	790 (373)	860 (406)	930 (439)



STEAM SEPARATOR

APPLICATION DATA

- Steam, compressed air, and gas systems
- Steam mains
- Before steam turbines
- Hot air batteries
- Heat exchangers
- Duplicators
- Boilers
- Kilns
- Radiators
- Sterilizers
- Drip stations before temperature control or pressure reducing valves
- Steam inlets to process equipment which require dry saturated steam
- Before filters and on the compressed air supply to sensitive instruments
- Laundry Processes

ORDERING CODE

MODEL # (Must be 2 Digits)	CONNECTIONS	RATING (Must be 4 Digits)	—	SIZE
example: <u>E</u> <u>S</u>	<u>I</u>	<u>0150</u>	—	<u>C</u>
ES - Eliminator	T - NPT	0150 - 150#		C - 1/2
	W - Socketweld	0300 - 300#		D - 3/4
	F - Flanged	0600 - 600#		E - 1
				F - 1 1/4
				G - 1 1/2
				H - 2
				J - 2 1/2
				K - 3
				M - 4
				P - 6

Installation Tip: Always install a Steam Trap (i.e.: NFT, FTN, Max-Flo, Dura-Flo) after the Steam Separator
SEE PAGE 32

ELIMINATOR SERIES STEAM & AIR SEPARATOR

Pressures to 990 PSIG (68.2 barg)
Temperatures to 650°F (344°C)

Removal of Entrained Contaminants - Extracts nearly all moisture and solids above 10 microns

Long Service Life - No moving parts mean less wear and corrosion

High Capacities - Up to 35,000 lbs./hr steam

Steel bodies and internals - Withstand unfavorable conditions and water hammer

Drain Outlet Below Condensate Level - Prevents steam leakage

Optimal Gravity Discharge - Drain located directly below the line

Maintenance Free - Regular maintenance is not required

Steam or Air Service

OPTIONS

- Optional Insulation Jacket

MAXIMUM OPERATING CONDITIONS

1/2" - 2" NPT & SW
Class 400 - 990 psig (68.2 barg) @ 100°F (34°C)

2 1/2" - 6" ANSI 150 Flanged
Class 150 - 285 psig (19.6 barg) @ 100°F (34°C)

2 1/2" - 6" ANSI 300 Flanged
Class 300 - 740 psig (51.0 barg) @ 100°F (34°C)

2 1/2" - 6" ANSI 600 Flanged
Class 400 - 990 psig (68.2 barg) @ 100°F (34°C)

MODELS

- ES-150 - 150 psig ANSI Flanged
- ES-300 - 300 psig ANSI Flanged
- ES-600 - 600 psig NPT, Socketweld, ANSI Flanged

NOTE: This is a fabricated product. Custom designs are available. Please call factory for details.

Installation Tip: Always install a Y Strainer between the Steam Separator and Trap.

OPERATION

When the vapor enters the steam separator, a series of baffles change its flow direction several times. During this process, the baffles in the housing collect impinged water droplets that are carried in the system. Gravity allows the accumulated water droplets and

other foreign particles to fall to the drain and exit the system through a steam trap. The remaining steam in the system is clean and dry, allowing improved and maintained performance.

ELIMINATOR SERIES STEAM SEPARATOR

SPECIFICATION

Steam Separator shall have an internal baffle that does not exceed an equivalent length of pipe. The Steam Separator shall be installed in a horizontal pipe configuration with the drain directly below the line. The Steam Separator shall have an NPT bottom drain on which a mechanical constant flow steam trap shall be installed.

MATERIALS OF CONSTRUCTION

Body(½" to 2") Carbon Steel	ASTM SA53
	(2½" to 6") Carbon Steel	ASTM SA53
End CapsCarbon Steel	ASTM A-234 WPB
CouplingCarbon Steel	ASTM A-105
BaffleCarbon Steel	ASTM SA53
	Stainless Steel	Optional
PlugCarbon Steel	ASTM A105
End Connections:		
	(½" to 2") Carbon Steel	ASTM A105
	(2½" to 6") Carbon Steel	ASTM A105

SIZING INFO
PAGE 139

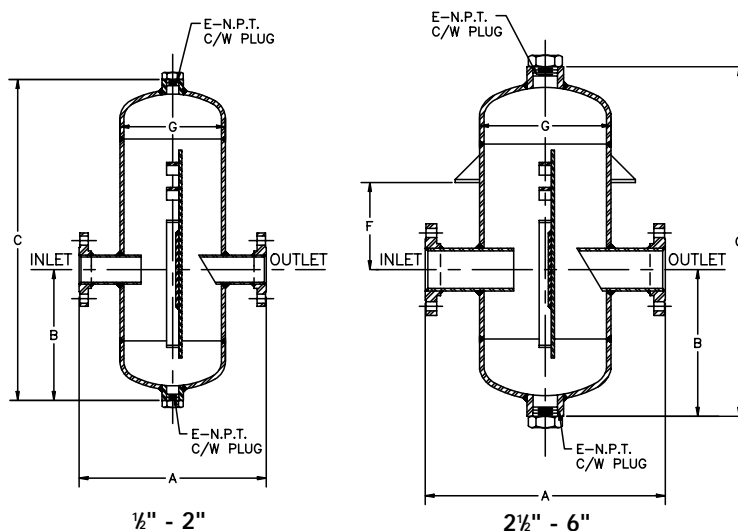

Connections:
½" - 2" SW & NPT or 2½" - 6" Flanged

- Call factory for sizing information. Please provide the following:
1. Steam or Compressed Air System
 2. Flow Rate (lb/Hr) ____
 3. Separator Connection Size ____
 4. System Pressure ____

DIMENSIONS inches (mm) AND WEIGHTS pounds (kg)

Pipe Size	Connection	A	B	C	E	F	G	Weight
1/2	NPT/SW	3½ (218)	5¼ (132)	10⅞ (269)	¾ (20.3)	—	6 (152.4)	9 (4.1)
3/4	NPT/SW	8¾ (224)	5⅞ (150)	12⅞ (307)	¾ (20.3)	—	6 (152.4)	10 (4.5)
1	NPT/SW	9¾ (236)	6 (152)	14⅞ (358)	¾ (20.3)	—	6 (152.4)	19 (8.6)
1-1/4	NPT/SW	9¾ (238)	7⅞ (180)	16⅞ (416)	¾ (20.3)	—	6 (152.4)	30 (13.6)
1-1/2	NPT/SW	11⅞ (287)	7⅞ (193)	19 (483)	1 (25.4)	—	8 (203)	43 (19.5)
2	NPT/SW	11⅞ (295)	11⅞ (206)	20⅞ (523)	1 (25.4)	—	8 (203)	50 (22.7)
2-1/2	Flanged ANSI 150	22½ (572)	9⅞ (239)	24½ (622)	1 (25.4)	7⅞ (180)	10 (254)	109 (49.4)
	Flanged ANSI 300	22½ (572)	9⅞ (239)	24½ (622)	1 (25.4)	7⅞ (180)	10 (254)	112 (50.8)
	Flanged ANSI 600	22½ (572)	9⅞ (251)	25⅞ (650)	1 (25.4)	7⅞ (180)	10 (254)	113 (51.3)
3	Flanged ANSI 150	25⅞ (643)	12 (305)	28⅞ (726)	2 (50.8)	8 (203)	10 (254)	163 (73.9)
	Flanged ANSI 300	25⅞ (643)	12 (305)	28⅞ (732)	2 (50.8)	8 (203)	10 (254)	169 (76.7)
	Flanged ANSI 600	25⅞ (643)	12⅞ (323)	29⅞ (759)	2 (50.8)	8 (203)	10 (254)	189 (85.7)
4	Flanged ANSI 150	29 (737)	12⅞ (320)	31¼ (792)	2 (50.8)	8 (203)	12 (305)	237 (108)
	Flanged ANSI 300	29 (737)	12⅞ (320)	31¼ (792)	2 (50.8)	8 (203)	12 (305)	256 (116)
	Flanged ANSI 600	29 (737)	13¼ (335)	31¼ (792)	2 (50.8)	8 (203)	12 (305)	297 (135)
6	Flanged ANSI 150	35¾ (909)	12⅞ (312)	36¾ (932)	2 (50.8)	11⅞ (290)	16 (406)	365 (166)
	Flanged ANSI 300	35¾ (909)	12⅞ (315)	36⅞ (937)	2 (50.8)	11⅞ (290)	16 (406)	401 (182)
	Flanged ANSI 600	35¾ (909)	13 (330)	37¾ (960)	2 (50.8)	11⅞ (290)	16 (406)	551 (250)



DRAINER NLD SERIES

FREE-FLOATING LEVER DRAINER

ALL STAINLESS STEEL

Pressures to 400 psig (28 barg)
 Temperatures to 500°F (260°C)
 Loads to 2000 lbs./hr.

Automatic and Positive Drain — Effectively removes liquids from compressed air systems with minimum air loss and rapid shutoff on load conditions

Inexpensive — Low maintenance and initial cost

Stainless Steel Body — Durable heavy wall construction provides years of reliable service and resists corrosion and freezing.

Maintenance Free — Sealed body design prevents tampering and no gaskets or adjustments are necessary

All Stainless Steel Construction — Long lasting, rugged, and corrosion resistant

Direct Lever Action — Ensures proper seating under all operating conditions

APPLICATIONS

- Removes liquid from air or gas systems
- Removes liquid from air or gas storage

MODELS

- **NLD**- Free Float liquid Drainer

Canadian Registration Number*-OE10389•5ADD1

*CRN is only available up to 307 psig

ORDERING CODE

Model			Dash	Inlet Size	Outlet Size	Orifice
N	L	D	-	2	1	3
1	2	3	4	5	6	7

MODEL - Position 1 - 3
 NLD - Drainer Series

DASH - Position 4

INLET SIZE - Position 5
 2 = 3/4"

OUTLET SIZE - Position 6

1 = 1/2"

ORIFICE - Position 7

2 = 3/32"

3 = 5/64"

OPERATION

The all stainless steel drainer removes liquids from a pressurized air /gas system. The float and lever-operated design provides instantaneous and automatic adjustment to variations in flow and pressure.

As liquid enters the top of the drainer, it starts to lift the float up and open the valve. When the liquid is removed, it falls back down to close the valve. This cycle repeats as more liquid accumulates in the drainer.

DRAINER NLD SERIES

FREE-FLOATING LEVER DRAINER

ALL STAINLESS STEEL

SPECIFICATION

The liquid drain trap shall be of a float type design with all stainless steel components including, sealed body, seat and valve. It is available in 3/4" x 1/2" NPT connections.

MATERIALS OF CONSTRUCTION

BodyAISI 304 SS
 ConnectorsAISI 304 SS
 FloatAISI 304 SS
 LeverAISI 304 SS
 Bracket ClipAISI 304 SS
 ValveHardened Chrome Steel AISI D3
 Valve SeatHardened Chrome Steel AISI D3

MAXIMUM OPERATING CONDITIONS

PMO: Maximum Operating Pressure See table below
 PMA: Maximum Allowable Pressure 400 psi (28 bar)
 TMA: Maximum Operating Temperature 500°F (260°C)

Orifice	Max. Operating Pressure psi (bar)
1/8"	175 psi (12)
3/32"	300 psi (21)
5/64"	400 psi (28)

CRITICAL DIMENSIONS

Height7 1/4"
 Diameter2 3/4"
 Wall0.05"
 Pipe ConnectionsNPT

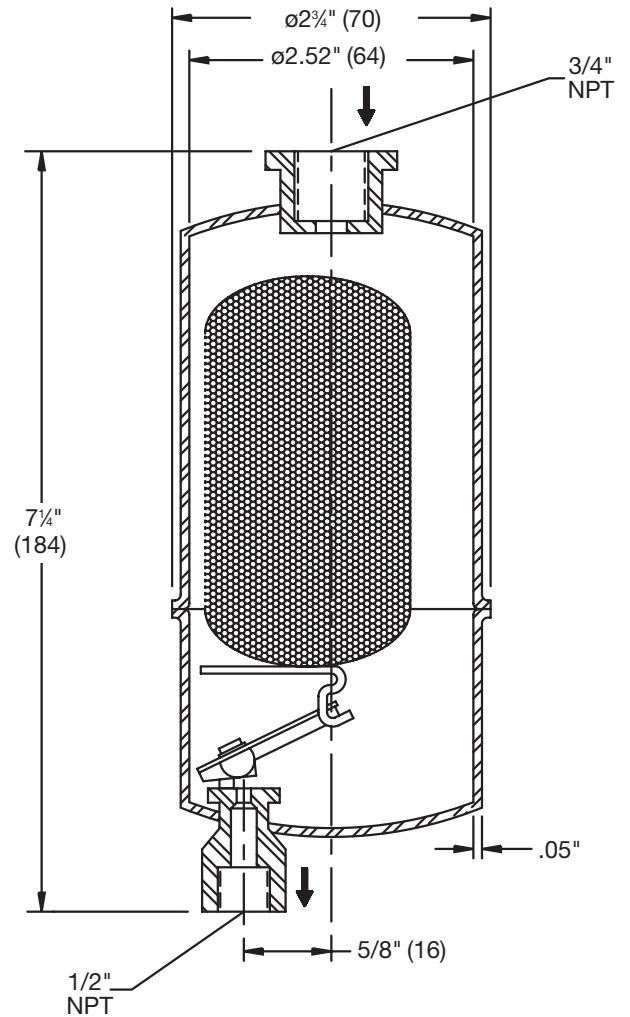

VENTER NAV SERIES

FREE-FLOATING LEVER AIR VENTER

Pressures to 400 psig (28 barg)
Temperatures to 500°F (260°C)



Automatic and Positive Vent — Effectively provides automatic positive venting of Air/Gas under pressure

Inexpensive — Low maintenance and initial cost

Stainless Steel Body — Durable heavy wall construction provides years of reliable service and resists corrosion and freezing.

Maintenance Free — Sealed body design prevents tampering and no gaskets or adjustments are necessary

All Stainless Steel Construction — Long lasting, rugged, and corrosion resistant

Direct Lever Action — Ensures proper seating under all operating conditions

APPLICATIONS

- For Hot or Cold Water and Non-Viscous Liquid Systems
- For the removal of air and other gases
 - From hydronic heating,
 - From cooling systems,
 - Liquid chilling operations, and other light liquid services.

MODELS

- **NAV-** Free Float Air / Gas Vents

Canadian Registration Number*-OE10389•5ADD1

*CRN is only available up to 307 psig

ORDERING CODE

Model				Inlet Size	Outlet Size	Orifice
N	A	V	-	2	1	1
1	2	3	4	5	6	7
MODEL - Position 1 - 3 NAV - Venter Series				OUTLET SIZE - Position 6 1 = 1/2"		
DASH - Position 4				ORIFICE - Position 7 1 = 1/8"		
INLET SIZE - Position 5 1 = 1/2" 2 = 3/4"				2 = 3/32" 3 = 5/64"		

OPERATION

The all stainless steel air/gas vent allows for the removal of air/gas from a pressurized liquid system. The float and lever-operated design provides instantaneous and automatic adjustment to variations in flow and pressure.

The valve is closed in the presence of liquid. As air/gas enters the bottom of the venter, the float begins to drop and open the valve. When air is removed, it lifts back up to close off the valve. This cycle repeats as more air/gas builds up.

VENTER NAV SERIES

FREE-FLOATING LEVER AIR VENTER

SPECIFICATION

The air/gas vent shall be of a float-type design capable of discharging air or gas in a pressurized liquid system. All components including sealed body, seat, and valve are made of stainless steel and are available with a 1/2" or 3/4" NPT inlet and 1/2" NPT outlet.

MATERIALS OF CONSTRUCTION

Body	AISI 304 SS
Connectors	AISI 304 SS
Float	AISI 304 SS
Lever	AISI 304 SS
Bracket Clip	AISI 304 SS
Valve	Hardened Chrome Steel AISI D3
Valve Seat	Hardened Chrome Steel AISI D3

MAXIMUM OPERATING CONDITIONS

PMO: Maximum Operating Pressure	See table below
PMA: Maximum Allowable Pressure	400 psi (28 bar)
TMA: Maximum Operating Temperature	500°F (260°C)

Orifice	Max. Operating Pressure psi (bar)*
1/8"	175 (12)
3/32"	300 (21)
5/64"	400 (28)

* Good for liquids with SG of 1.0 but will also work down to SG of 0.75

CRITICAL DIMENSIONS

Height	7 1/4"
Diameter	2 3/4"
Wall05"
Pipe Connections	NPT

